

# Electrical Line Extension Policy



Adopted by City Ordinance No. 3911 on January 17, 2017

City of Gillette - Electrical Services Division  
611 N. Exchange Avenue  
Gillette, WY 82716

TELEPHONE: (307)686-5277  
FAX: (307)686-6564  
[www.gillettewy.gov](http://www.gillettewy.gov)

# Table of Contents

## Section I – General Information

Purpose.....	4
Definitions .....	4
Departments, Phone Numbers and Addresses .....	4
Applicable Regulations.....	5
Application for Electrical Distribution System Extension .....	5
Application for Electrical Service Line System Extension .....	5
Permitting, Inspection and Acceptance.....	5
Customer Equipment Compatibility & Protection.....	6
Easements .....	6
Access & Right of Way .....	7

## Section II – Distribution Systems

General Information.....	7
Distribution System Upgrades .....	7
Distribution System Extensions .....	8
Customer Responsibilities .....	8
Utility Responsibilities.....	8
Conduit Specifications .....	8
Conduit Installation.....	9
Riser Poles.....	9
Primary Voltage Junction Boxes and Switch Bases .....	9
Transformer Pads .....	10
Utility Equipment Protection.....	10
Secondary Voltage Pedestals .....	10
Street Lights.....	11
Joint Use of Trench.....	11
Surface Restoration.....	11

## Section III – Customer Service Line Extension

General Information.....	11
Utility Provided Service Line.....	11
Customer Provided Service Line – Underground.....	12
Service Line Upgrades, Modifications & Relocations .....	12
Multiple Services per Lot.....	12

Disconnection & Reconnection of Service.....	12
Temporary Service.....	13
<b>Section IV – Mobile Home Parks (MHP)</b>	
New Mobile Home Parks.....	13
Existing Mobile Home Parks.....	13
<b>Section V – Metering</b>	
General.....	13
Meter Sockets.....	14
Mounting of Meter Sockets.....	14
Instrument Rated Metering.....	14
Utility Approved Current Transformer Enclosure Alternatives.....	15
<b>Appendix 1 – Standard Drawings</b>	
<b>Appendix 2 – Available Fault Current Data</b>	
<b>Appendix 3 – Net Metering</b>	
<b>Appendix 4 – Capital Contribution Fee</b>	

# Section I - General Information

---

## Purpose

These standards have been prepared for the design and extension of the City's electrical distribution and service line system. It will set forth requirements, obligations and financial responsibilities for the Utility and the Customer. The City of Gillette Electrical Engineering Division will be responsible for all designs that affect the extension or modification of the electrical distribution and service line system. The City of Gillette encourages all customers in need of assistance to contact the City of Gillette Electrical Engineering Division at 307-686-5277.

## Definitions

- Utility: The responsible department within the City of Gillette acting in its capacity to serve the citizens of Gillette electric power.
- Customer: Citizen or entity requiring electrical service. This may be a developer, contractor or the actual end user.
- Distribution System: Shall be that portion of the electrical utility infrastructure that serves more than one customer or distributes primary voltage.
- Service Line System: Shall be that portion of the utility or customer infrastructure that serves customer(s).
- NEC: Current edition of the National Electric Code as adopted by the City of Gillette.
- NESC: Current edition of the National Electric Safety Code.
- Point of Service: Shall be the point where the customer owned equipment attaches to the utilities owned equipment. The exact point of service will be defined in these standards. All designs, installation and costs past the point of service are the customer's responsibility.
- Final Established Grade: Shall be the staked elevation determined by a licensed Land Surveyor.
- Departments, Phone numbers and Addresses

## City of Gillette – Contact Information

Electrical Engineering Division  
611 N Exchange Ave  
Gillette, WY 82716  
307-686-5277 (Main Office)  
307-687-2530 (Field Inspection)  
eeprojects@gillettewy.gov

City of Gillette Central Warehouse  
800 N Burma Ave  
Gillette, WY 82716  
307-686-5263 (Main Office)

Planning Division  
201 E 5<sup>th</sup> Street, 2<sup>nd</sup> Floor  
Gillette, WY 82716  
307-686-5281 (Main Office)

Building Inspection  
201 E 5<sup>th</sup> Street, 2<sup>nd</sup> Floor  
Gillette, WY 82716  
307-686-5260 (Main Office)

## **Applicable Regulations**

- NEC: All new, remodeled, or modified construction requiring electrical service within the City of Gillette shall conform to applicable provisions of the NEC.
- NESC: All extensions of the City's electrical distribution system shall be installed to meet the minimum requirements of the NESC.
- City of Gillette Code: All new, remodeled, or modified construction requiring electrical service within the City of Gillette shall conform to applicable provisions of the City of Gillette Code.
- City of Gillette Standard Construction Specifications: All extensions and modifications of the City's electrical distribution system shall be installed following the latest version of the City of Gillette Standard Construction Specifications (i.e., warranty, safety, etc.).
- Conflicts in Regulations: These standards are issued with the intent of complying with all applicable codes, ordinances, and standards; however in the case of a conflict, the most stringent code, ordinance, or standard will supersede. If there is a conflict between the applicable regulations contact the City of Gillette Electrical Engineering Division for clarification.

## **Application for Electrical Distribution System Extension**

- All electrical service system extensions or upgrades require an application submitted through the Planning Division.
- It is also important that the Electrical Engineering Division be provided as much information as early as possible so all provisions required by the customer can be met.

## **Application for Electrical Service Line System Extension**

- All electrical service line system extensions or upgrades require an application submitted through Building Inspection or the Planning Division.
- It is also important that the Electrical Engineering Division be provided as much information as early as possible so all provisions required by the customer can be met.

## **Permitting, Inspection and Acceptance**

- Electrical Permits: service line extensions and upgrades are under NEC jurisdiction and permits shall be obtained from Building Inspection.
- Electrical Permit to Construct: prior to the installation of any portion of the electrical distribution system, the customer shall obtain an "Electrical Permit to Construct" from the Electrical Engineering Division. This permit shall be required for the release of City material issued from the City's Warehouse.
- Electrical Service System Inspection: All new or upgraded services lines shall be inspected by Building Inspection.
- Electrical Service Line Extension Acceptance: Building Inspection shall issue a "green tag" when all aspects of the service have been installed to meet the NEC. The Electrical Services Division will be notified that the service has passed inspection and is ready for connection to the Utility System.

- Electrical Distribution System Inspection: All installations on the electrical distribution system shall be inspected by an Electrical Engineering Division representative prior to the acceptance of the installation. Call the Electrical Engineering field inspection line to schedule necessary inspections.
- Electrical Distribution Extension Acceptance: The customer must submit compaction test results and any other data relevant to the installation of the distribution system as required by the Electrical Engineering Division. A final inspection will be completed by the Electrical Engineering Division with the customer to ensure all design criteria have been met.
- Variations to Design: When conditions are encountered during construction which require changes to the provided system design.
- After project acceptance, the Distribution Extension will be completed by the Electrical Services Division.

### **Customer Equipment Compatibility & Protection**

- The Customer's electrical equipment and devices are required to have characteristics such that the Utility's distribution system is efficiently utilized and shall not interfere with the Utility's service or power quality to other customers (i.e. harmonics, power factor, etc.).
- The Utility reserves the right to inspect and test any equipment connected to its distribution system and to require any information necessary to determine the operational characteristics of the equipment.
- The Customer's equipment shall be designed to perform adequately within the standard voltage ranges and frequency provided on the Utility System.
- Prior to the installation of any large motorized equipment over 75 horsepower, the Customer shall submit specifications to the Utility regarding this equipment.
- Prior to the installation of sensitive computerized equipment, the Customer shall submit specifications to the Utility regarding this equipment (this does not pertain to normal household appliances or personal computers).
- Electric Service provided by the Utility may be subject to voltage disturbances which will not normally affect the performance of typical electrical equipment; however, voltage sensitive equipment may be impacted by these voltage disturbances. It is the Customer's responsibility to provide power conditioning devices necessary for protection of their equipment.
- Electric Service provided by the Utility may be subject to a "loss of phase" type of disturbance. It is the Customers responsibility to provide protective devices for their equipment.

### **Easements**

- All utility owned equipment with the exception of the customer's service line, shall be installed in a recorded easement, platted easement or in a dedicated right-of-way.
- It is the customer's responsibility to provide all required easements to the Utility at no cost. All required easements shall be recorded at the Campbell County Clerk's office. Documentation of this recorded easement must be provided to the Electrical Engineering Division prior to the Utility providing service to the customer.

- Minimum width of easements shall be ten (10) feet with the exception of a street light circuit which may be five (5) feet. Larger easements may be required if determined by the Electrical Engineering Division.

### **Access & Right of Way**

- The Customer shall grant free access to the customer's premises for the Utility to complete all projects and to maintain continuity of service.

## **Section II - Distribution Systems**

---

### **General Information**

- The Utility will provide electrical capacity to new developments for all electrical distribution system extensions.
- All electrical distribution system extensions will be designed by the Electrical Engineering Division and installed underground.
- All electrical underground distribution system extensions shall be installed in conduit.
- The Customer responsibilities for new developments are outlined in the section titled 'Customer Responsibilities'.
- The Utility responsibilities for new developments are outlined in the section titled 'Utility Responsibilities'.
- The Customer shall be responsible for notifying affected property owners prior to the beginning of construction.
- Any exceptions to the Utility design shall be approved by the Electrical Engineering Division and paid for by the customer including all design, material, Utility labor and Utility equipment costs.
- Trenches 8" and less in width shall follow the City of Gillette Standard Construction Specifications Section 16000.
- Trenches larger than 8" in width shall follow City of Gillette Standard Construction Specifications Section 02220.
- Backfill and compaction of trenches larger than 8" in width shall follow City of Gillette Standard Construction Specifications Section 02225.
- Seeding and surface restoration shall follow City of Gillette Standard Construction Specifications Section 02900.

### **Distribution System Upgrades**

- Customers may request modifications of the system to the Electrical Engineering Division.
- The Customer will be responsible for all costs associated with the requested modifications including Utility labor, vehicle and equipment costs with the exception of any transformers, which will be provided by the Utility.

## **Distribution System Extensions**

### **Customer Responsibilities**

- Customer shall provide and install per project design:
  - Trench to required depth
  - Backfill and compact trench
  - Required conduit
  - Ground rods
  - Street light conductors and connectors
  - Compaction test(s), as required
  - Other components, as required
- Customer shall purchase from the City of Gillette Warehouse and install:
  - Equipment pads
  - Primary junction boxes
  - Secondary pedestals
  - Street light pedestals, poles, luminaires and photo eyes
  - Other components, as required
- Customer shall be invoiced from the Utility:
  - Primary cable
  - Secondary conductors
  - Grounding wire
  - Terminations and connectors
  - Other components, as required

### **Utility Responsibilities**

- Utility shall provide and install the following:
  - Project design and inspection
  - All transformers and switch cabinets within the development
  - Labor to install conductors, components and connectors
  - Equipment and vehicles associated with the installation of distribution system extensions

### **Conduit Specifications**

- PVC conduit shall be schedule 40 grade.
- P.E. conduit shall be SDR 13.5. (Note: only Utility approved connectors shall be used when transitioning from P.E. conduit to any other type of conduit.)
- Horizontal sweeps shall be 48" radius GRC (Galvanized Rigid Conduit) conduit for primary cable installations.
- All sweeps shall be 24" radius 2.5" PVC conduit for secondary conductor.
- All sweeps shall be 12" radius 1" PVC conduit for street light conduit.
- Sweeps shall be 24" inch radius GRC with 10' length of GRC attached horizontally for primary voltage junction boxes and transformer box pads.



- Conduit into primary voltage vaults shall be installed into the provided knockouts of the vault. Exception; as approved by the Electrical Engineering Division, a 24” GRC sweep with a 10’ length of GRC conduit may be used in place of primary vault knockouts.
- The following sizes of conduit shall be required for the corresponding installations:
  - Three-Phase primary - 4/0 cable: 6” conduit
  - Three-Phase primary - 1/0 cable: 4” conduit
  - Single-Phase primary - 1/0 cable: 2.5” conduit
  - Secondary distribution – 350 mcm cable: 4” conduit
  - Secondary distribution – 4/0 cable: 2.5” conduit
  - Service runs: 2” conduit (depending on service size)
  - Street Lighting circuits: 1” conduit

### **Conduit Installation**

- All trenching and backfill shall be in accordance with the latest edition of the City of Gillette Standard Construction Specifications.
- All conduit installed by the Customer shall be inspected by the Utility after installation and prior to backfill.
- Conduit for primary voltage cable shall be installed with a minimum of 48 inches of cover based on the Final Established Grade.
- Conduit for secondary voltage cable shall be installed with a minimum of 24 inches of cover based on the Final Established Grade.
- All conduit systems shall have a nylon pull string with a minimum tensile strength of 200 pounds installed. The pull string shall not be installed prior to the complete conduit system being installed. The Utility shall be contacted by the Customer prior to the installation of pull string.

### **Riser Poles**

- The Customer shall furnish all conduit material necessary, including conduit straps, for the Utility to construct the riser. The first 10 feet above the ground line on all risers shall be GRC, the remaining conduit for the riser shall be schedule 40 PVC. This includes both primary and secondary voltage risers.
- A weather head shall be provided by the Customer for all secondary riser applications.

### **Primary Voltage Junction Boxes and Switch Bases**

- The Customer shall provide excavation, backfill, compaction and installation of junction boxes and switch bases
- Compaction testing shall be in accordance with the latest version of the City of Gillette Standard Construction Specifications.
- The Customer shall have a minimum of one compaction test over the compacted trench at all equipment pad and junction box locations. Additional compaction tests may be required at the discretion of Electrical Engineering.

- The top of all sweeps shall not extend more than 4" above the bottom of the ground sleeve. Sweeps shall not be cut off without prior approval of Electrical Engineering.
- Extreme caution must be exercised during compaction so as not to damage or deform the ground sleeve or junction box during construction, wheel compaction using a backhoe or trencher shall not be permitted.
- Drawings will be provided to the Customer with the detailed Electrical Engineering design for conduit and ground rod(s) placement in equipment pads/bases.
- All installed equipment pads shall be a minimum of 5' from fire hydrants.
- Gravel shall be installed in the bottom of equipment. Consisting of 1-1/2" minus crushed limestone, at a depth of 4".
- Burial depth of equipment to be determined in the field by Electrical Engineering based on the Final Established Grade.

### **Transformer Pads**

- The Customer shall provide excavation, backfill, compaction and installation of transformer pads.
- Compaction testing shall be in accordance with the latest version of the City of Gillette Standard Construction Specifications.
- The Customer shall have a minimum of one compaction test over the compacted trench at equipment pad location. Additional compaction tests may be required at the discretion of Electrical Engineering.
- The Customer may incorporate the transformer pad as an integral portion of a total equipment pad with the approval of the Electrical Engineering Division.
- Transformer pads shall be located a minimum of 3' from any obstructions on the sides and the back. The front of the transformer will require a minimum of 10' of unobstructed area.
- Drawings will be provided to the Customer with the detailed Electrical Engineering design for conduit and ground rod placement in transformer pads.
- All installed transformer pads shall be a minimum of 5' from fire hydrants.
- The top of transformer pads shall be installed at 6" above the Final Established Grade.

### **Utility Equipment Protection**

- Bollards, when required by Electrical Engineering, shall be provided and installed by Customer for utility equipment to protect from physical harm.
- A standard drawing for bollards will be provided with the detailed Electrical Engineering design.

### **Secondary Voltage Pedestals**

- Adequate compaction at each pedestal location shall be completed by the Customer.
- Pedestals shall be installed above Final Established Grade as per engineered drawings.
- Pedestals installed in concrete or asphalt shall be set flush with the top of the surface and shall be incidental drive over rated.
- Drawings will be provided to the Customer with the detailed Electrical Engineering design for conduit placement.

## Street Lights

- Drawings will be provided to the Customer with the detailed Electrical Engineering design for street light and pedestal locations, conduit size and route, and conductor size and type.
- All street light poles shall be installed such that centerline of the pole is plumb.
- Customer shall compact around the pole as it is backfilled to ensure it remains plumb.
- Street light foundation design shall be provided by the Electrical Engineering Division.
- Any Sonotube used to install street light bases shall be removed from the concrete base on the portion above ground.

## Joint Use of Trench

- Dry utility conduits and cables may be placed in the same trench with the Utility conduits and cables.
- In a joint use trench, a minimum of 12" of vertical separation shall be maintained between conduits owned by the Utility and any other installed conduit owned by another entity.
- Non wire utilities such as gas, water and sewer shall not be installed in a joint trench with electrical and communication conduits.
- Gas lines shall have a minimum 2' radial clearance from dry utilities.

## Surface Restoration

- After installation is complete, the Customer is responsible for all surface restoration within their development and any other areas of disturbance associated with their project.

# Section III - Customer Service Line Extension

---

## General Information

- Trenches 8" and less in width shall follow the City of Gillette Standard Construction Specifications Section 16000.
- Trenches larger than 8" in width shall follow City of Gillette Standard Construction Specifications Section 02220.
- Backfill and compaction of trenches larger than 8" in width shall follow City of Gillette Standard Construction Specifications Section 02225.
- Seeding and surface restoration shall follow City of Gillette Standard Construction Specifications Section 02900.

## Utility Provided Service Line

- The Utility shall provide and install one single phase service up to 320 amps per lot.
- The route of the service line shall be mutually agreed upon between the Customer and the Utility.
- The route shall be as short as practical and shall avoid all obstructions.
- The Point of Service for all underground service lines shall be the line side of the Customer owned meter socket.
- The Point of Service for all overhead service lines shall be the connections at the weather head.

- The Customer shall provide and install the appropriate size meter base with a main breaker built in for single phase services.
- The Utility shall consult with the Customer to determine a mutually agreed upon location of the Customer owned meter socket.
- The Customer shall provide the Utility access at all times as may be required for maintenance or service restoration.
- The Customer is responsible for all permit fees and Capital Contribution Fees at the time of obtaining a permit from the Building Inspection Division.
- At its discretion, the Utility may elect to install an overhead service within an overhead service area.

### **Customer Provided Service Line — Underground**

- The Customer is responsible for service above 320 amps in size for single phase service.
- The Customer is responsible for all three phase services and meter bases.
- The Customer shall install the three phase meter base along with a NEC approved disconnect.
- The Point of Service for all Customer owned services shall be the secondary connections at the Utility transformer or secondary pedestal, as determined by Electrical Engineering.
- The Customer shall provide the Utility access at all times as may be required for maintenance or service restoration.
- Service above 320 amps single phase and all three phase services shall be under the jurisdiction of the City of Gillette Building Inspection Division and shall be installed to NEC.
- The Customer is responsible for permit fees and Capital Contribution Fees at the time of obtaining a permit from the Building Inspection Division.

### **Service Line Upgrades, Modifications & Relocations**

- All service line upgrades, modifications or relocations are the Customer's responsibility and shall be coordinated through Electrical Engineering.
- The Customer is responsible for permit fees and any additional Capital Contribution Fees at the time of obtaining a permit from the Building Inspection Division.

### **Multiple Services per Lot**

- The Customer is responsible for all services for lots with more than one meter (i.e. a strip mall, four-plex or larger apartment buildings).
- The Point of Service for all Customer owned services shall be the secondary connections at the Utility transformer or secondary pedestal, as determined by Electrical Engineering.
- Any project requiring more than 6 meter/disconnects shall be installed to meet NEC and be inspected and approved by the City of Gillette Building Inspection Division.

### **Disconnection & Reconnection of Service**

- Only authorized Utility employees shall make connections or disconnections for all electric services.

## Temporary Service

- The Customer is responsible for all costs to install temporary service(s) to the Utility point of service.
- A location usable throughout the construction period shall be selected.
- Should relocation become necessary, it shall be treated as a separate temporary service and require an additional fee.
- Temporary service for construction sites shall be located such that the meter is protected from physical damage.
- Permit for temporary service shall be obtained from Building Inspection.
- An account for temporary service shall be opened with Customer Service.
- Customer shall pay the current temporary service fee(s) to Customer Service.

## Section IV - Mobile Home Parks (MHP)

---

### New Mobile Home Parks

- The Customer shall install electrical systems in compliance with Utility construction standards following design provided by Electrical Engineering.
- The Customer shall install all service lines from transformer to meter pedestals.
- The Utility shall maintain service to each individual meter in the MHP. The point of service shall be the line side of the Customer owned meter pedestal.
- The Customer shall provide meter pedestals for each lot and this meter pedestal must comply with NEC.
- The Customer shall provide service from meter pedestal to the mobile home.
- The Customer owned meter pedestals and service line to the home shall be inspected by Building Inspection.
- The entire electrical system including meter pedestals shall be installed in permanent recorded easements.

### Existing Mobile Home Parks

- All upgrades to existing MHP services shall be in compliance with current Utility construction standards.

## Section V - Metering

---

### General

- The Utility's tariff, rate schedule and the NEC require the delivery of each type and class of electrical service through one meter to one customer at one location.
- Customers are not authorized to relocate any meter belonging to the Utility or interfere in any way with the meter, its connections, or operation. This shall include removal or tampering with meter seals.
- The meter must be installed outdoors at a location that is readily accessible to Utility employees.

- The meter shall be accessible and shall not be installed over window wells, under stairways, behind doors or in other unsafe locations.
- The meter and metering equipment shall be at least 36" horizontally from a gas meter.
- Minimum space shall be maintained in front of all metering in accordance with the NEC
- The Customer shall consult with the Utility to find the best location for the meter that will facilitate meter reading, testing and replacement of meters.
- If a meter is made inaccessible by the installation of a fence, enclosure or other obstruction, the Customer shall, at their expense, move the meter to an accessible location approved by the Utility or remove the obstruction.

## **Meter Sockets**

- Customer shall provide and install the meter socket for single phase service up to 320 amps. The meter socket shall have a main breaker built into the assembly.
- Customer shall purchase from the City of Gillette Warehouse and install meter sockets for single phase services 400 amps and above.
- Customer shall purchase from the City of Gillette Warehouse and install meter sockets for all three phase services.

## **Mounting of Meter Sockets**

- The meter shall have a mounting height such that the center of the meter is not less than 4' or more than 5' above the Final Established Grade immediately in front of the meter location.
- Meter sockets must be plumb and level in all directions and securely mounted to a rigid structure.
- Meter sockets mounted on a building must be secured to wall studs. Where it is not possible to mount to wall studs, blocking between wall studs of at least two 2x4's shall be used.
- Conductors shall be securely fastened to their respective terminals and must be installed in a manner that will not interfere with the installation of the meter cover.
- Metering equipment shall not be installed on or in Utility owned transformers.

## **Instrument Rated Metering**

- This type of metering applies to services over 320 amps single phase and 320 amps three phase.
- The Utility shall provide the current transformers to the Customer for all instrument rated services.
- The Customer shall provide and install an enclosure to house the current transformers.
- Minimum size required for current transformer enclosure shall be:
  - 36" x 36" x 8" for three phase services over 200 amps
  - 24" x 24" x 8" for single phase services over 320 amps.
- A larger size current transformer enclosure may be substituted if determined by the Customer's electrical professional.
- The Utility shall provide only window type current transformers. Customer provided current transformer enclosure shall accept only window type current transformers.
- Current transformers shall not be installed in Customer owned indoor switch gear.
- Current transformers shall not be installed in Utility owned transformers.

- Meter sockets shall not be installed on Utility owned transformers.
- The Utility shall be responsible for meter circuit wiring of all instrument rated meter installations.

### **Utility Approved Current Transformer Enclosure Alternatives**

- Alternative 1:
  - The Customer shall provide a transition cabinet rated for the service. Customer shall install Utility provided current transformers over the bus inside the transition cabinet. Customer shall install the meter socket purchased from the Utility on the transition cabinet.
  - The utility shall be responsible for meter circuit wiring within the transition cabinet.
- Alternative 2:
  - The Customer shall provide outdoor rated switchgear with a Utility compartment included to house Utility provided current transformers. Customer shall install the meter socket purchased from the Utility on the outside of the Customer provided outdoor rated switchgear.
  - The utility shall be responsible for meter circuit wiring within the outdoor rated switchgear.

# Appendix 1

---

## Standard Drawings

- Typical Trenching Detail
- Secondary Pedestal Installation
- Drive Over Secondary Pedestal Installation
- Single Phase Fiberglass Transformer Pad
- Three Phase Fiberglass 20' Transformer Pad
- Nordic Junction Box Ground Installation
- Switch Cabinet Base Installation
- Pad Mounted Equipment Clearances
- Equipment Placement – Front Lot Lines
- Equipment Placement – Rear Lot Lines
- Fire Hydrant Clearances
- Street Light Detail - Direct Bury – Residential
- Street Light & Foundation Detail – Highway
- Street Light & Foundation Detail – Shakespeare Acorn
- Typical Bollard Detail
- Meter Socket Installation
- CT Can Installation



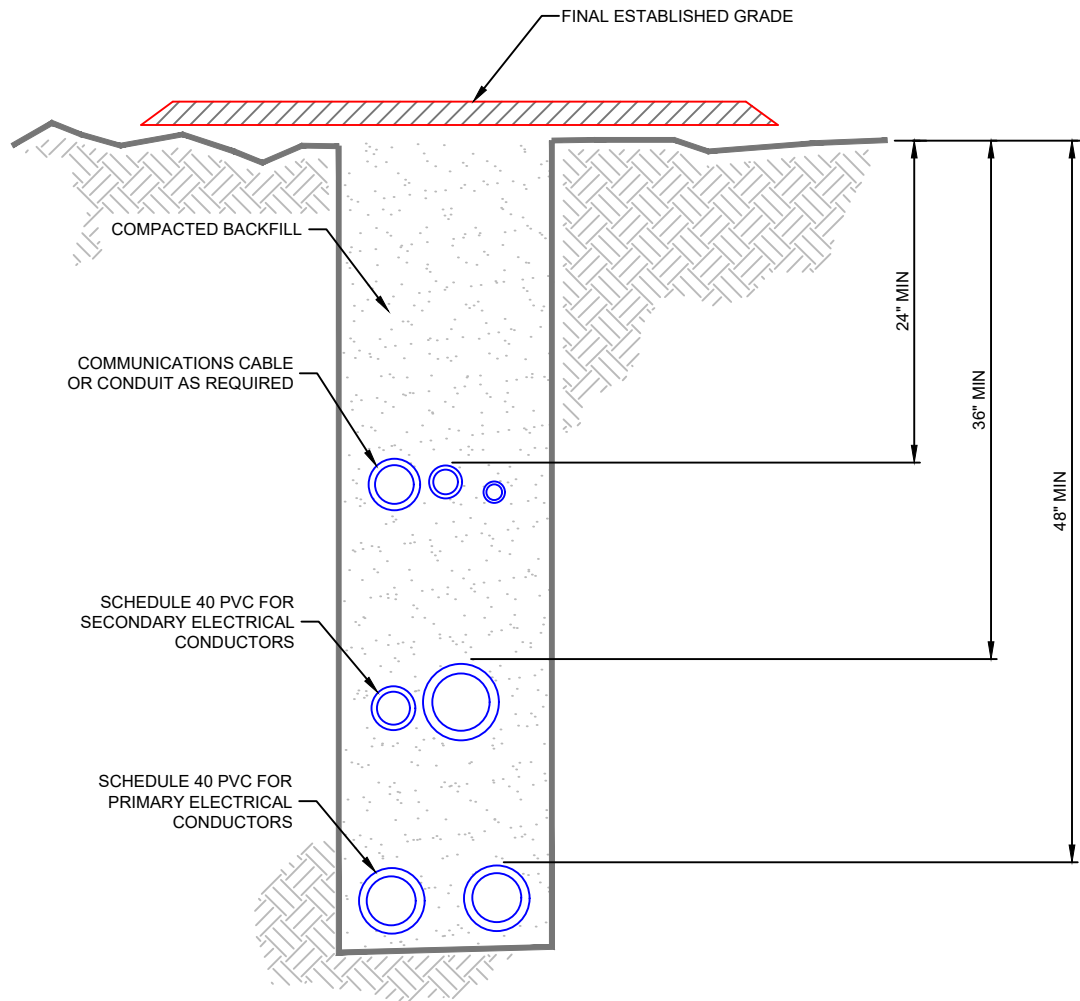

NOTE :

- \* 12" SEPARATION BETWEEN COMMUNICATIONS, SECONDARY CONDUCTOR AND PRIMARY CONDUCTOR UNLESS OTHERWISE APPROVED
- \* ALL CONDUIT TO BE SIZED AND REVIEWED BY APPROPRIATE UTILITY COMPANY
- \* TELEPHONE AND CABLE TELEVISION COMPANIES ARE TO BE CONTACTED TO INSURE CORRECT LOCATION AND INSTALLATION OF THEIR FACILITIES.

TELEPHONE REVIEWED BY: \_\_\_\_\_

CABLE TELEVISION REVIEWED BY: \_\_\_\_\_



City Of Gillette  
 Department of Utilities  
 Electrical Engineering Division  
 611 N Exchange Ave  
 Gillette, WY 82717  
 307.686.5277

# TYPICAL TRENCHING DETAIL

Date: 2016-02-11

Drawing: trench.dwg

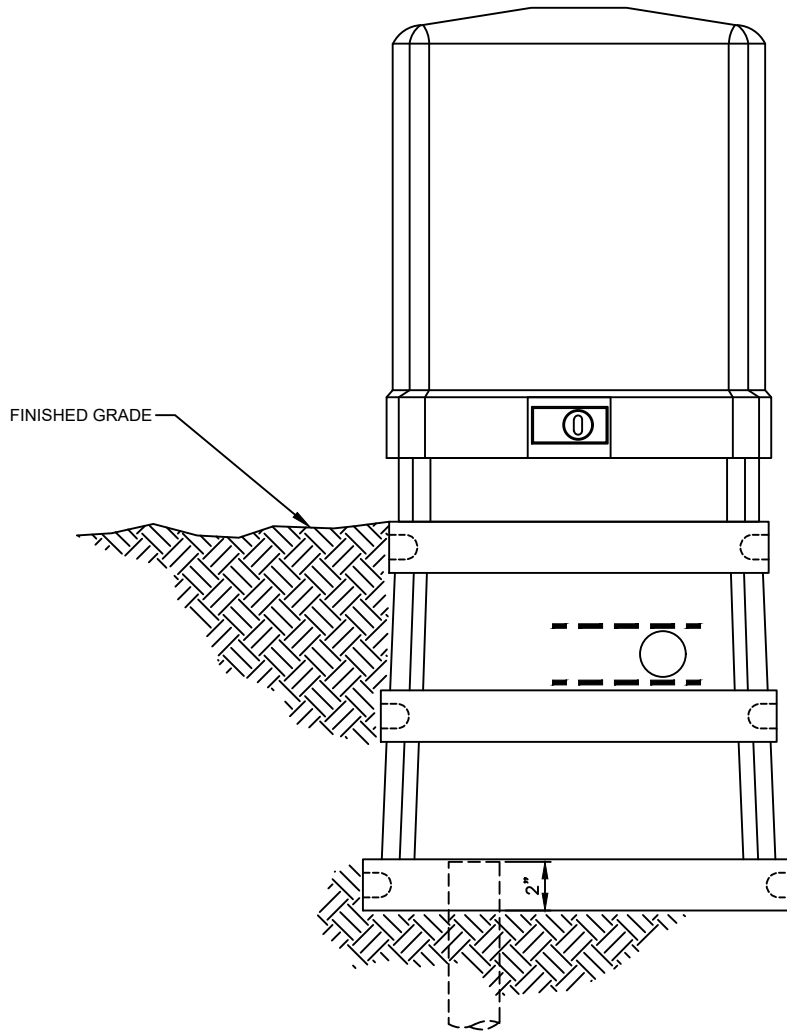

NOTE:

\* CONDUIT TO EXTEND 2" ABOVE THE BOTTOM OF THE PEDESTAL AND MUST BE PLACED 2" FROM LEFT OR RIGHT SIDE OF PEDESTAL

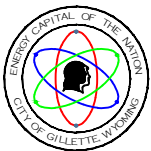

City Of Gillette  
 Department of Utilities  
 Electrical Engineering Division  
 611 N Exchange Ave  
 Gillette, WY 82717  
 307.686.5277

## SECONDARY PEDESTAL INSTALLATION

Date:  
 2016-02-11

Drawing:  
 ped-sec.dwg

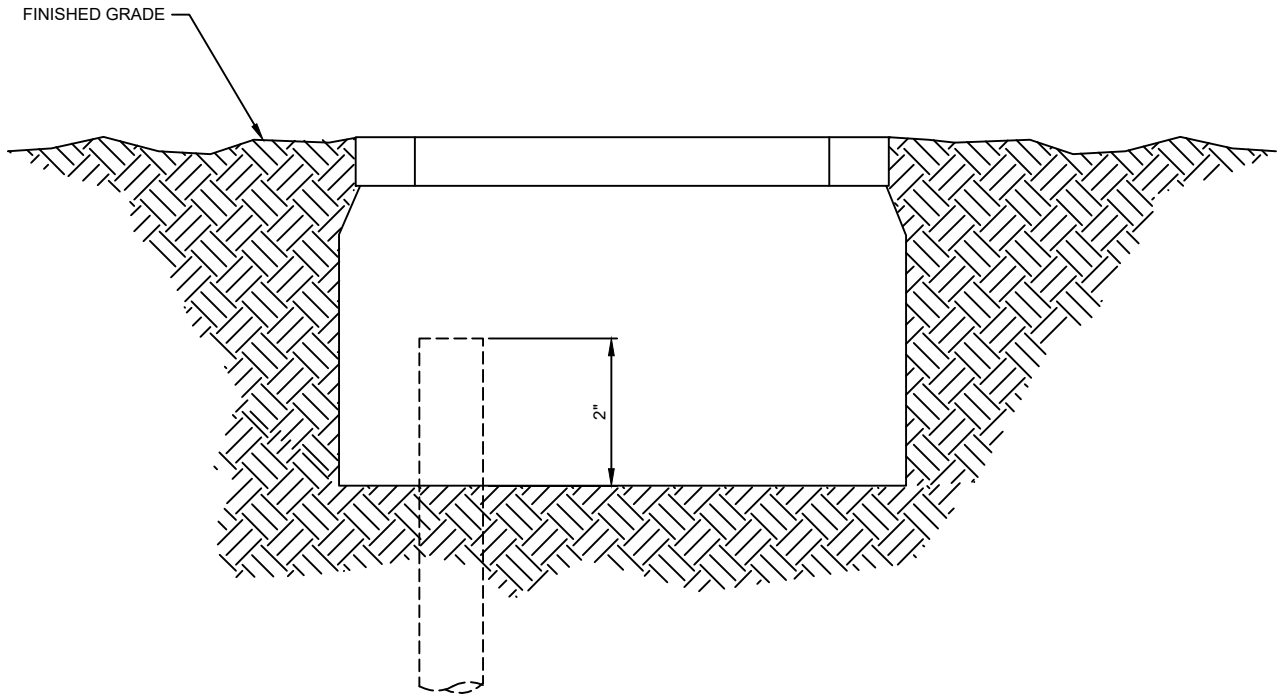

NOTE:

- \* CONDUIT TO EXTEND 2" ABOVE THE BOTTOM OF THE PEDESTAL AND MUST BE PLACED 2" FROM LEFT OR RIGHT SIDE OF PEDESTAL
- \* TOP OF PEDESTAL TO BE PLACED AT FINAL GRADE WHEN PLACED IN ASPHALT OR CONCRETE AND IS TO BE DRIVE OVER RATED

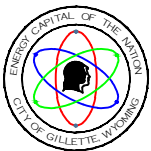

City Of Gillette  
 Department of Utilities  
 Electrical Engineering Division  
 611 N Exchange Ave  
 Gillette, WY 82717  
 307.686.5277

## DRIVE OVER SECONDARY PEDESTAL INSTALLATION

Date:  
 2016-03-24

Drawing:  
 ped-sec-drovr.dwg

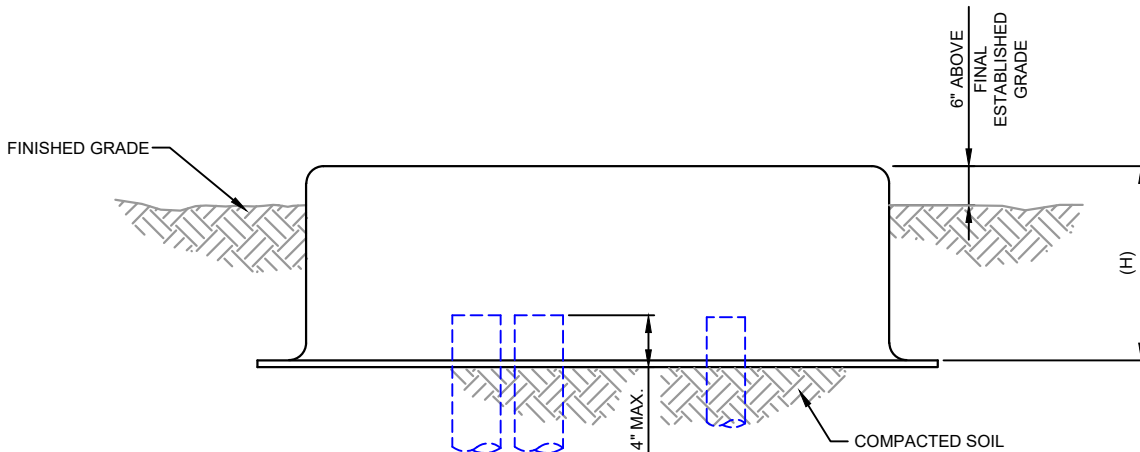
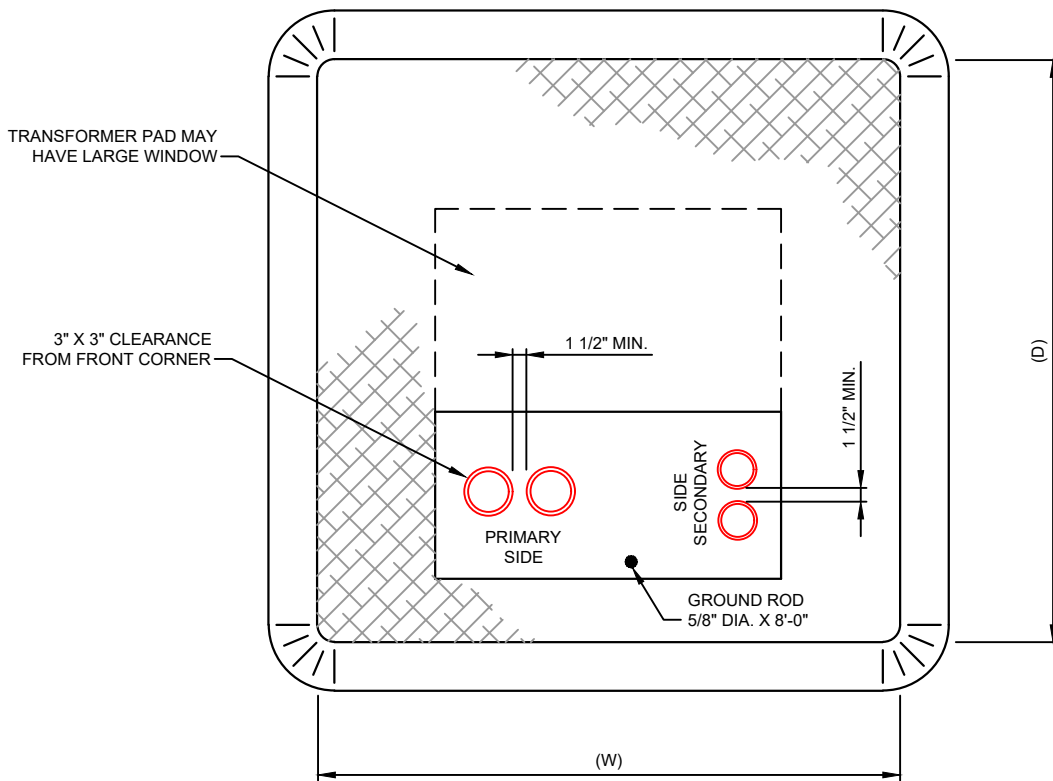

NOTE:

- \* PRIMARY CONDUIT TO BE INSTALLED AT EXTREME FRONT LEFT HAND SIDE OF WINDOW
- \* SECONDARY CONDUIT TO BE INSTALLED AT EXTREME FRONT RIGHT HAND SIDE OF WINDOW
- \* CONDUIT NOT TO EXTEND ABOVE 4" FROM THE BOTTOM OF THE PAD AND IS TO BE INSIDE THE WINDOW (OPENING) OF THE PAD
- \* 1-1/2" MINIMUM SEPARATION BETWEEN CONDUITS
- \* COMPACTION TEST IS TO BE DONE BEFORE THE PAD IS SET AND AFTER REPLACING BACKFILL DUE TO OVER EXCAVATING
- \* DIMENSION OF THE PAD VARIES PER DEPTH  
 15" (H) X 37 1/2" (W) X 43" (D) - PLACE CONDUITS WITHIN 5" OF FRONT OPENING  
 16" (H) X 42" (W) X 48" (D)  
 32" (H) X 42" (W) X 48" (D)



City Of Gillette  
 Department of Utilities  
 Electrical Engineering Division  
 611 N Exchange Ave  
 Gillette, WY 82717  
 307.686.5277

# SINGLE PHASE FIBERGLASS TRANSFORMER PAD

Date: 2016-06-13

Drawing: tr1-fg-pad.dwg

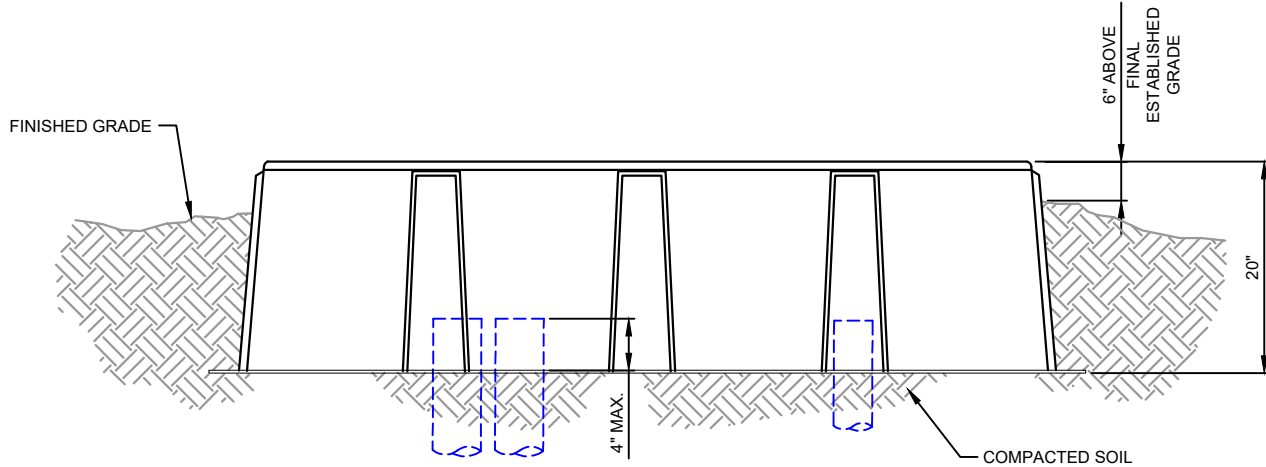
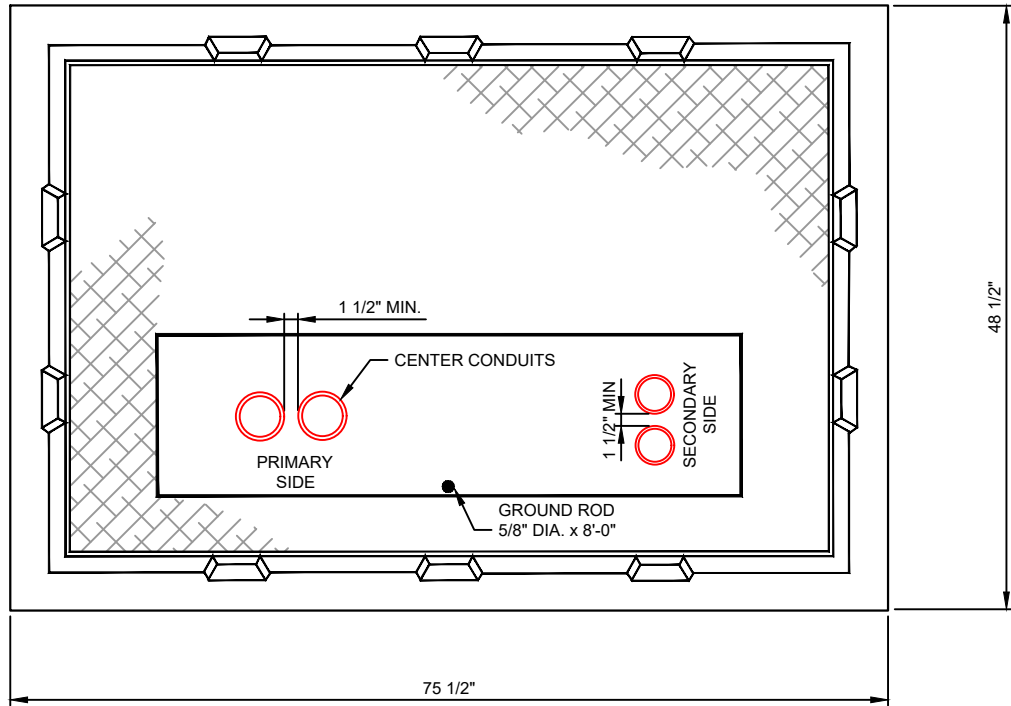

NOTE:

- \* PRIMARY CONDUIT TO BE INSTALLED AT EXTREME LEFT HAND SIDE OF WINDOW
- \* SECONDARY CONDUIT TO BE INSTALLED AT EXTREME RIGHT HAND SIDE OF WINDOW
- \* CONDUIT NOT TO EXTEND ABOVE 4" FROM THE BOTTOM OF THE PAD AND IS TO BE INSIDE THE WINDOW (OPENING) OF THE PAD
- \* 1-1/2" MINIMUM SEPARATION BETWEEN CONDUITS
- \* COMPACTION TEST IS TO BE DONE BEFORE THE PAD IS SET AND AFTER REPLACING BACKFILL DUE TO OVER EXCAVATING

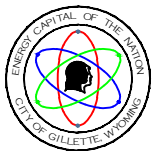

City Of Gillette  
 Department of Utilities  
 Electrical Engineering Division  
 611 N Exchange Ave  
 Gillette, WY 82717  
 307.686.5277

## THREE PHASE FIBERGLASS 20" TRANSFORMER PAD

Date: 2016-02-11

Drawing: tr3-fg-pad.dwg

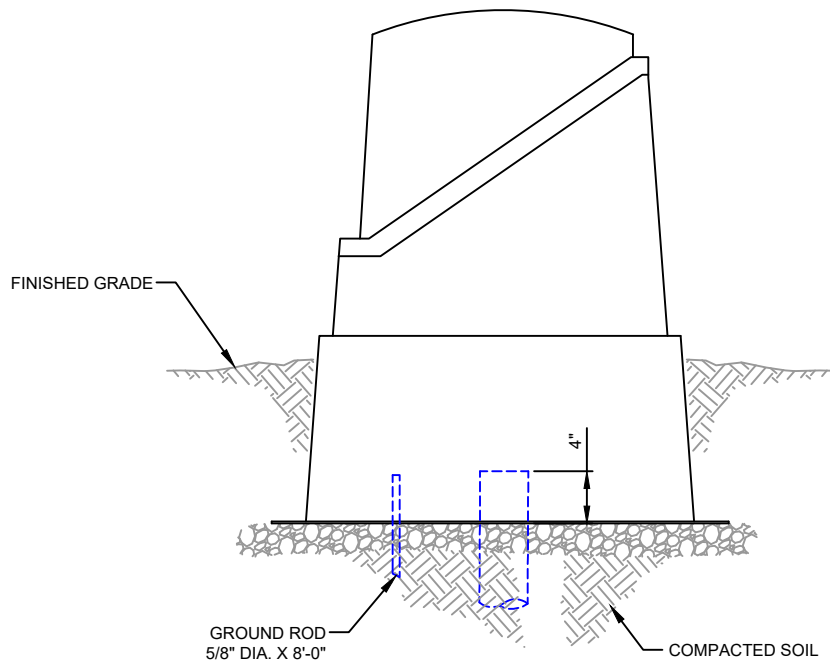
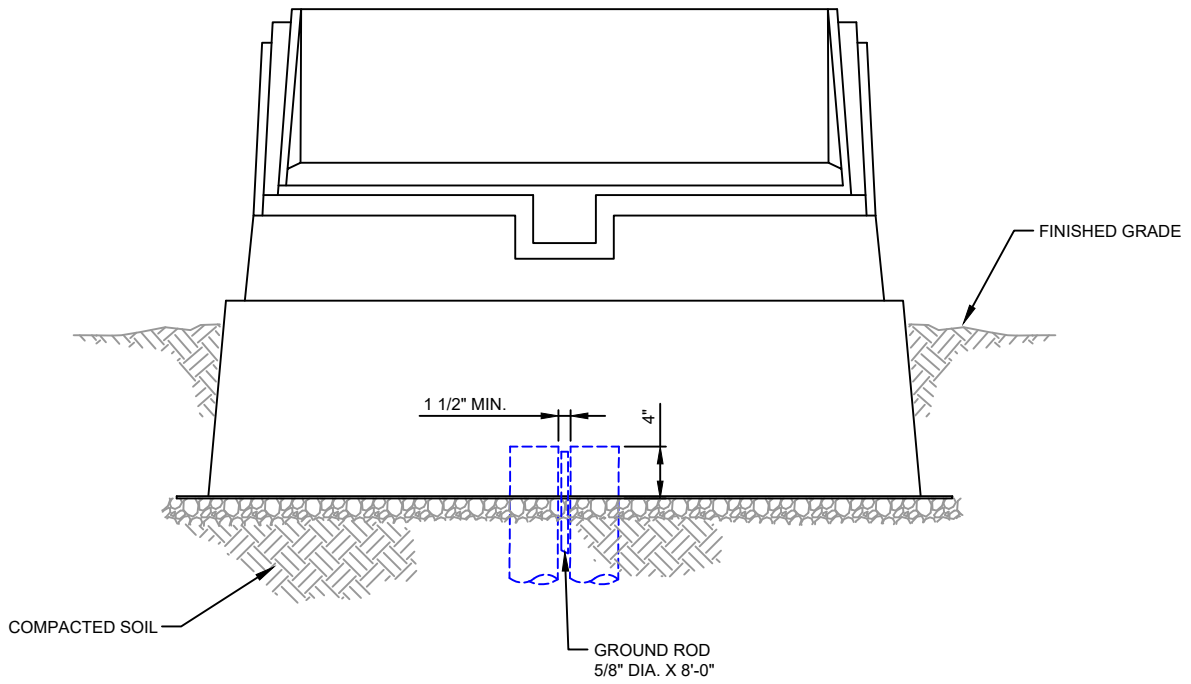

NOTE:

- \* CONDUIT NOT TO EXTEND ABOVE 4" FROM THE BOTTOM OF THE PAD
- \* 1-1/2" MINIMUM SEPARATION BETWEEN CONDUITS
- \* COMPACTION TEST TO BE DONE BEFORE J-BOX IS SET
- \* CONDUIT TO BE CENTERED INSIDE WINDOW OF PAD

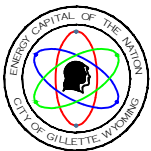

City of Gillette  
 Department of Utilities  
 Electrical Engineering Division  
 611 N Exchange Ave  
 Gillette, WY 82717  
 307.686.5277

## NORDIC JUNCTION BOX GROUND INSTALLATION

Date: 2016-03-24  
 Drawing: jbox-nordic.dwg

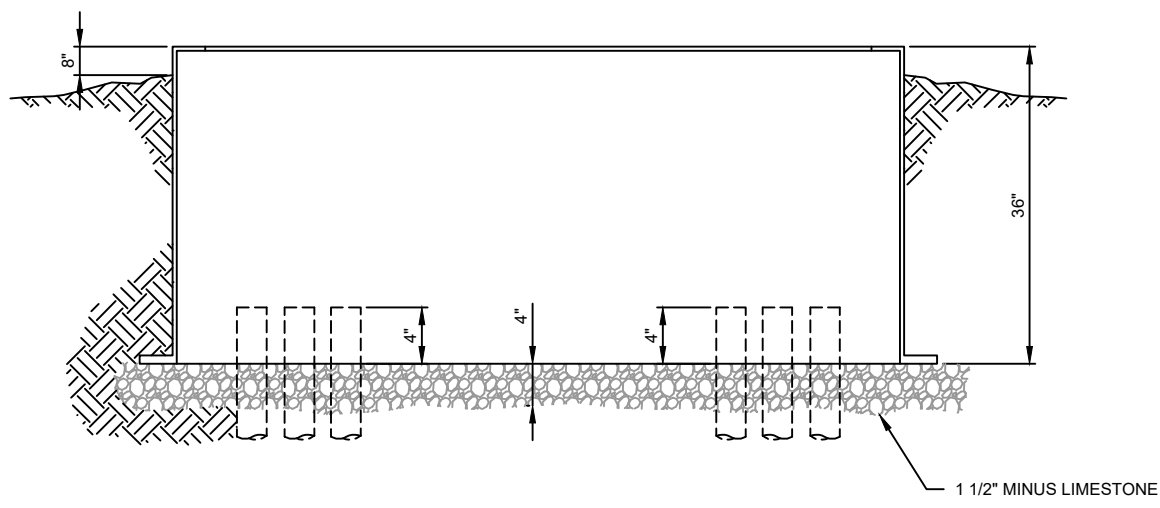
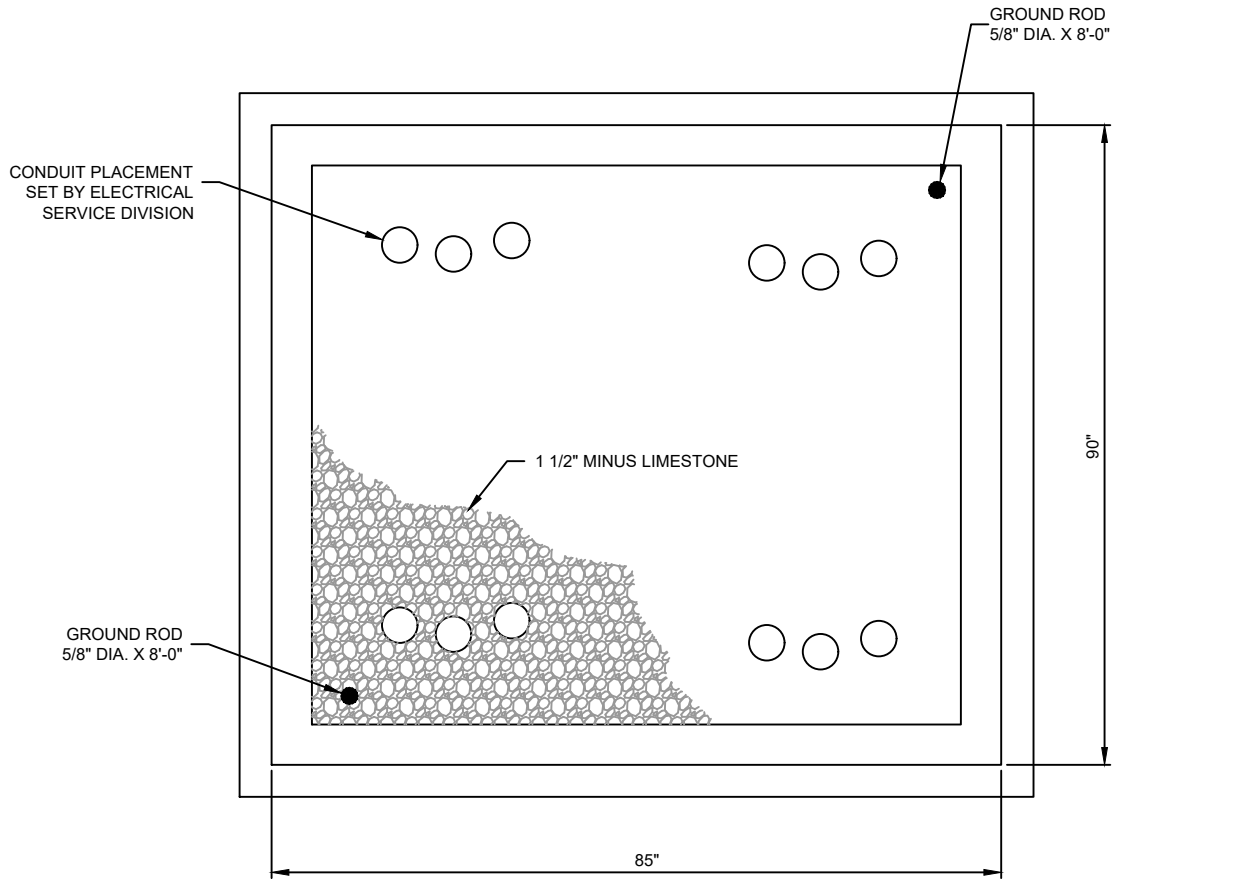

- NOTE :
- \* TOP OF SWITCH CABINET BASE IS TO BE PLACED 8" ABOVE FINISHED GRADE
  - \* TOP OF CONDUIT SWEEPS ARE TO BE 4" ABOVE GRAVEL
  - \* CONDUIT PLACEMENT TO BE DETERMINED BY CITY STAFF
  - \* 4" OF 1 1/2" MINUS LIMESTONE TO BE PLACED AFTER COMPACTION TEST IS DONE AND BEFORE BASE IS SET

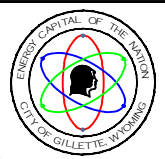

City Of Gillette  
 Department of Utilities  
 Electrical Engineering Division  
 611 N Exchange Ave  
 Gillette, WY 82717  
 307.686.5277

## SWITCH CABINET BASE INSTALLATION

Date: 2016-02-11  
 Drawing: sw-cab-base.dwg

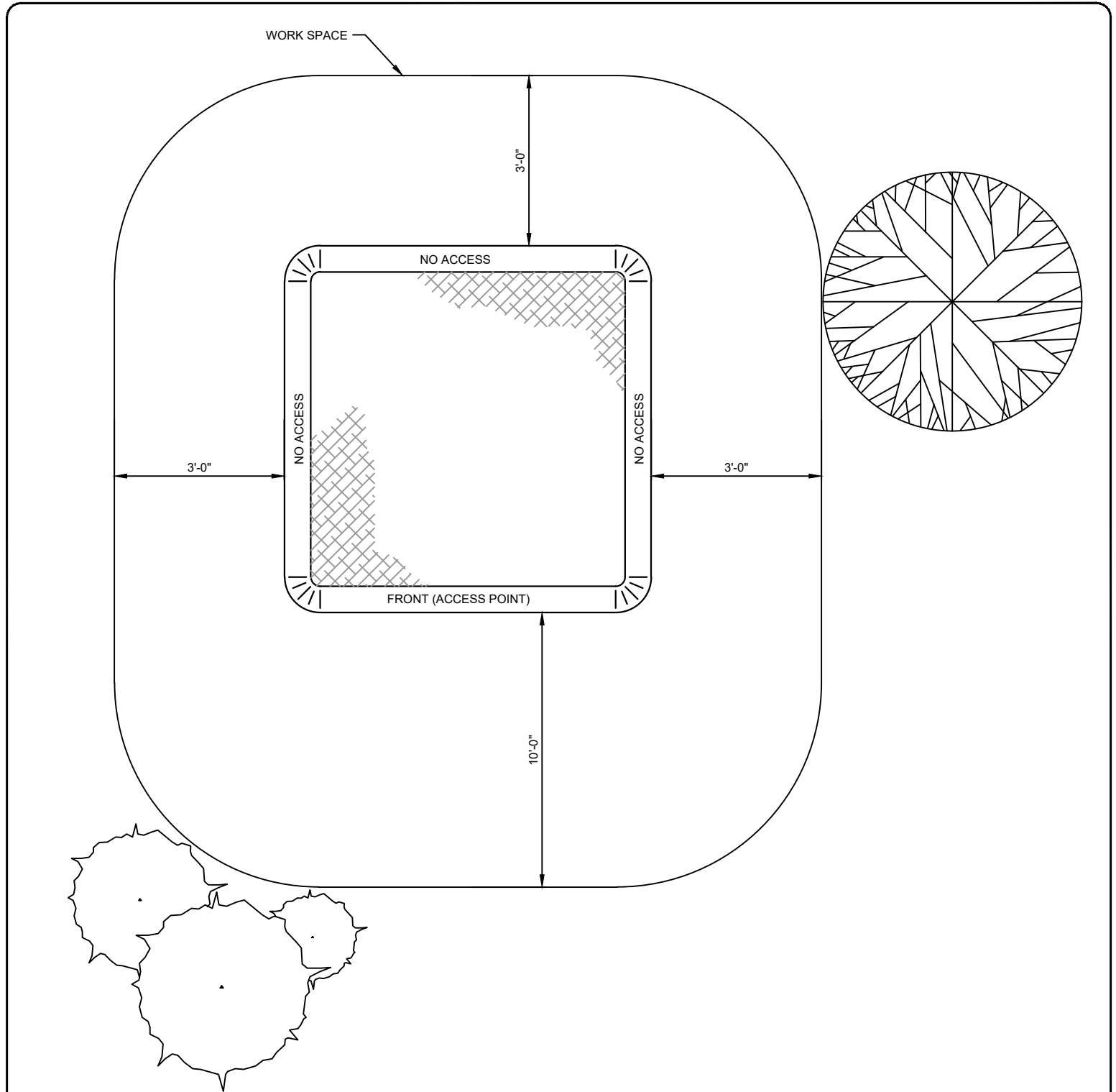

**NOTE:**

- \* 10 FOOT CLEAR SPACE IS REQUIRED IN FRONT OF ALL ACCESS DOORS OF ALL PAD MOUNTED EQUIPMENT
- \* 3 FOOT CLEAR SPACE IS REQUIRED ON THE SIDES AND REAR OF ALL PAD MOUNTED EQUIPMENT
- \* FOR MULTIPLE PAD MOUNT EQUIPMENT AREAS, CITY ELECTRICAL WILL DETERMINE NECESSARY SEPARATION DISTANCE
- \* NO VEGETATION IS PERMITTED INSIDE WORK SPACE AREA

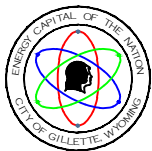

City Of Gillette  
 Department of Utilities  
 Electrical Engineering Division  
 611 N Exchange Ave  
 Gillette, WY 82717  
 307.686.5277

## PAD MOUNTED EQUIPMENT CLEARANCES

Date: 2016-02-11

Drawing: ut-clear-pdmnt.dwg



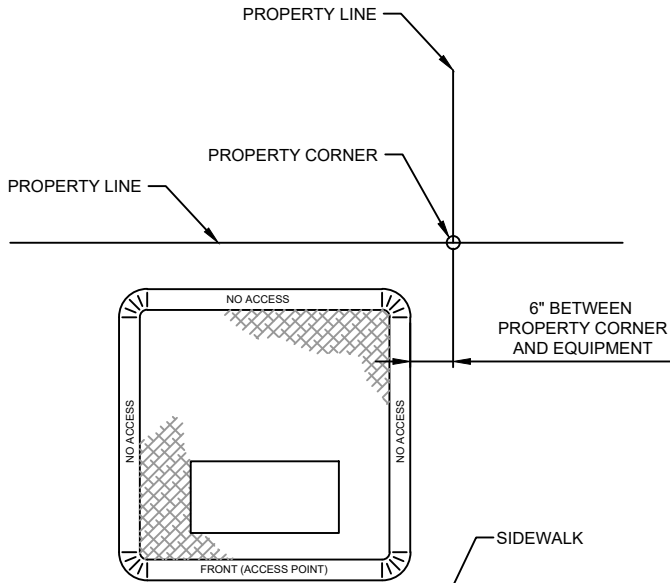

TRANSFORMER

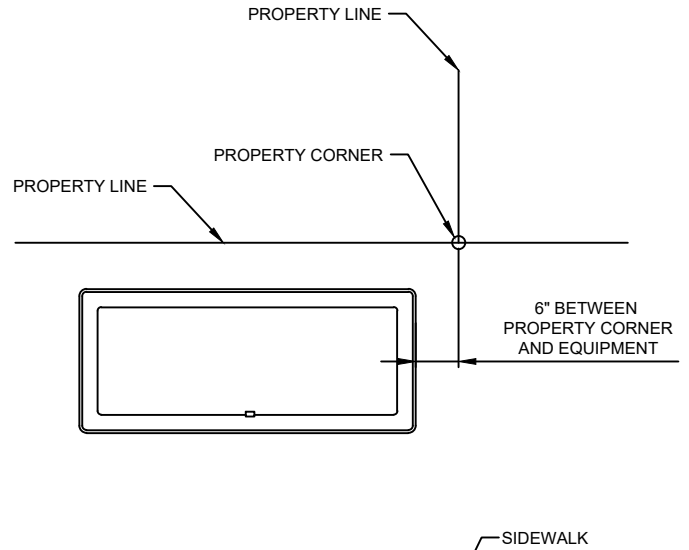

JUNCTION BOX

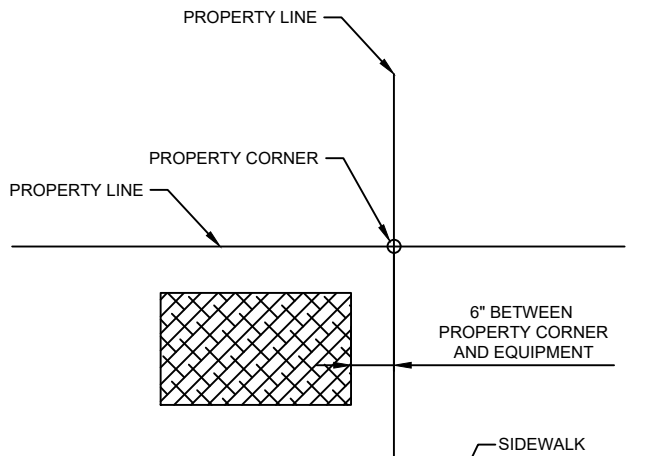

SECONDARY PEDESTAL

NOTE:

- \* EQUIPMENT IS TO BE PLACED FACING TOWARDS THE BACK OF CURB BETWEEN THE SIDEWALK/CURB AND FRONT PROPERTY LINE FOR ALL PAD MOUNTED EQUIPMENT BEING PLACED ALONG FRONT LOT LINES
- \* PLACE EQUIPMENT TO ONE SIDE OF THE PROPERTY CORNER
- \* IN AREAS WITH MULTIPLE PAD MOUNTED EQUIPMENT, CITY ELECTRICAL UTILITY WILL DETERMINE THE SEPARATION DISTANCE
- \* PHONE AND CABLE TO BE PLACED ON OPPOSITE SIDE OF PROPERTY LINE

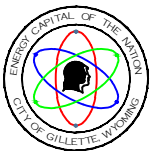

City Of Gillette  
 Department of Utilities  
 Electrical Engineering Division  
 611 N Exchange Ave  
 Gillette, WY 82717  
 307.686.5277

**EQUIPMENT PLACEMENT  
 FRONT LOT LINES**

Date:  
 2016-03-24

Drawing:  
 ut-place-fl.dwg

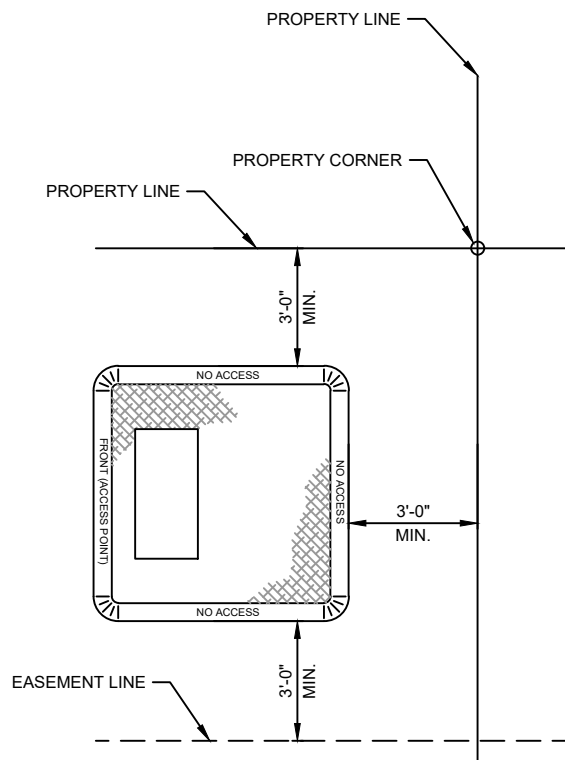

TRANSFORMER

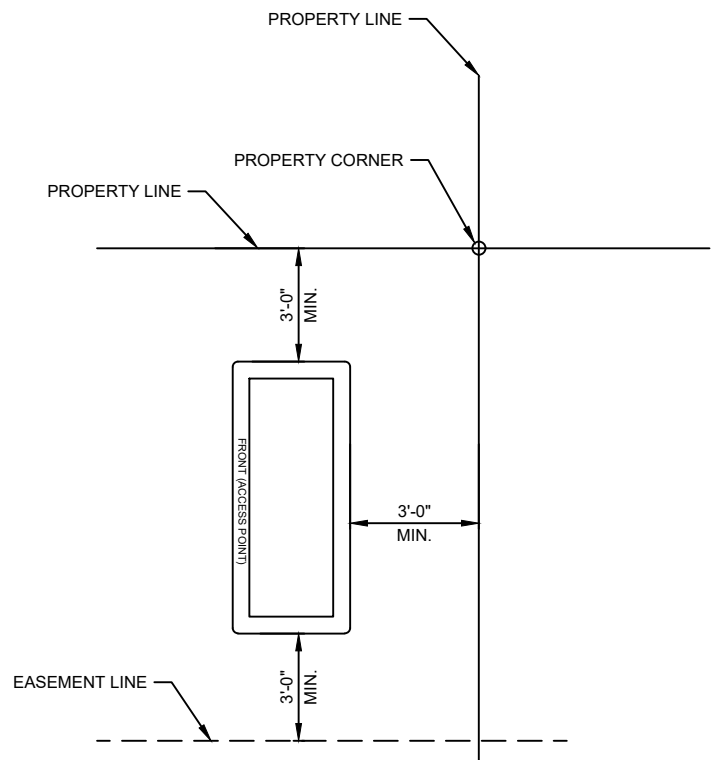

JUNCTION BOX

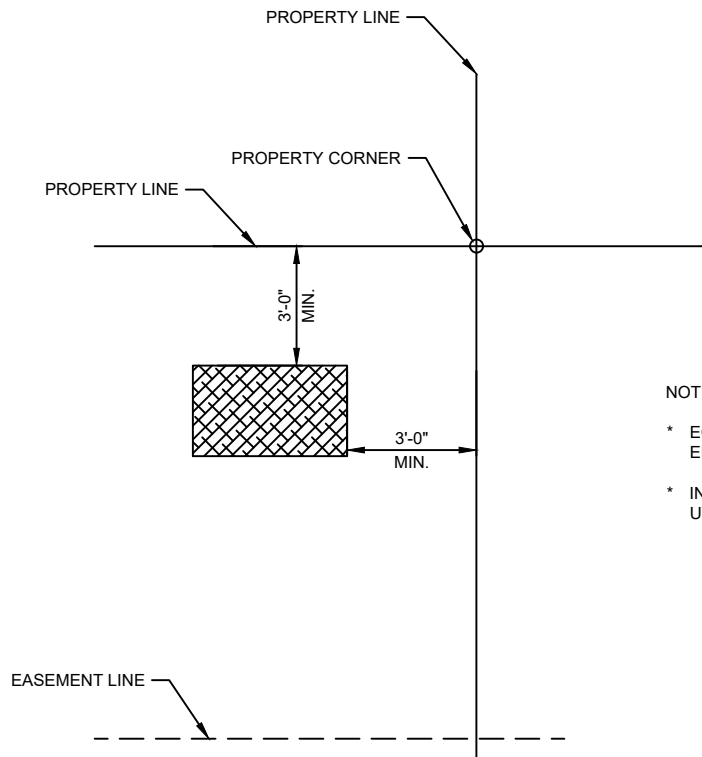

SECONDARY PEDESTAL

NOTE:

- \* EQUIPMENT PLACEMENT MAY BE ALTERED WITH THE CITY OF GILLETTE ELECTRICAL ENGINEERING APPROVAL
- \* IN AREAS WITH MULTIPLE PAD MOUNTED EQUIPMENT, CITY ELECTRICAL UTILITY WILL DETERMINE THE SEPARATION DISTANCE

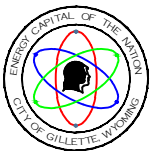

City Of Gillette  
 Department of Utilities  
 Electrical Engineering Division  
 611 N Exchange Ave  
 Gillette, WY 82717  
 307.686.5277

## EQUIPMENT PLACEMENT REAR LOT LINES

Date: 2016-02-11

Drawing: ut-place-rl.dwg

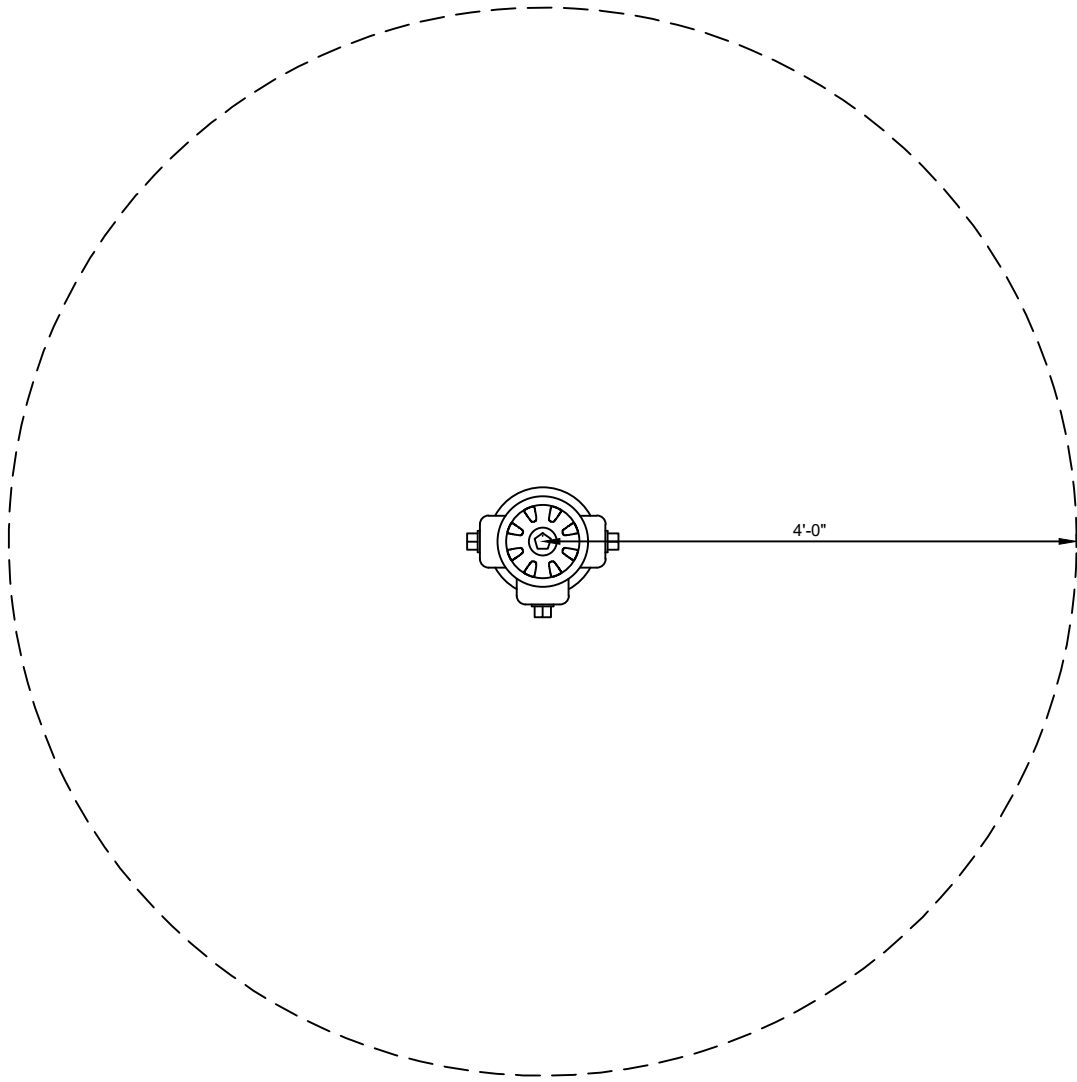

NOTE:

- \* 4 FOOT CLEARANCE IS REQUIRED AROUND ALL FIRE HYDRANTS
- \* FLUSH MOUNT SECONDARY PEDESTAL MAY BE INSTALLED WITHIN THE DESIGNATED AREA
- \* NO OTHER CITY ELECTRICAL EQUIPMENT (TRANSFORMERS, STREET LIGHTS, JUNCTION BOXES, ETC) CAN BE PLACED WITHIN THE DESIGNATED AREA

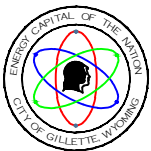

City Of Gillette  
Department of Utilities  
Electrical Engineering Division  
611 N Exchange Ave  
Gillette, WY 82717  
307.686.5277

## FIRE HYDRANT CLEARANCES

Date:  
2016-02-11

Drawing:  
ut-clear-fh.dwg

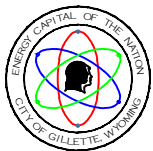
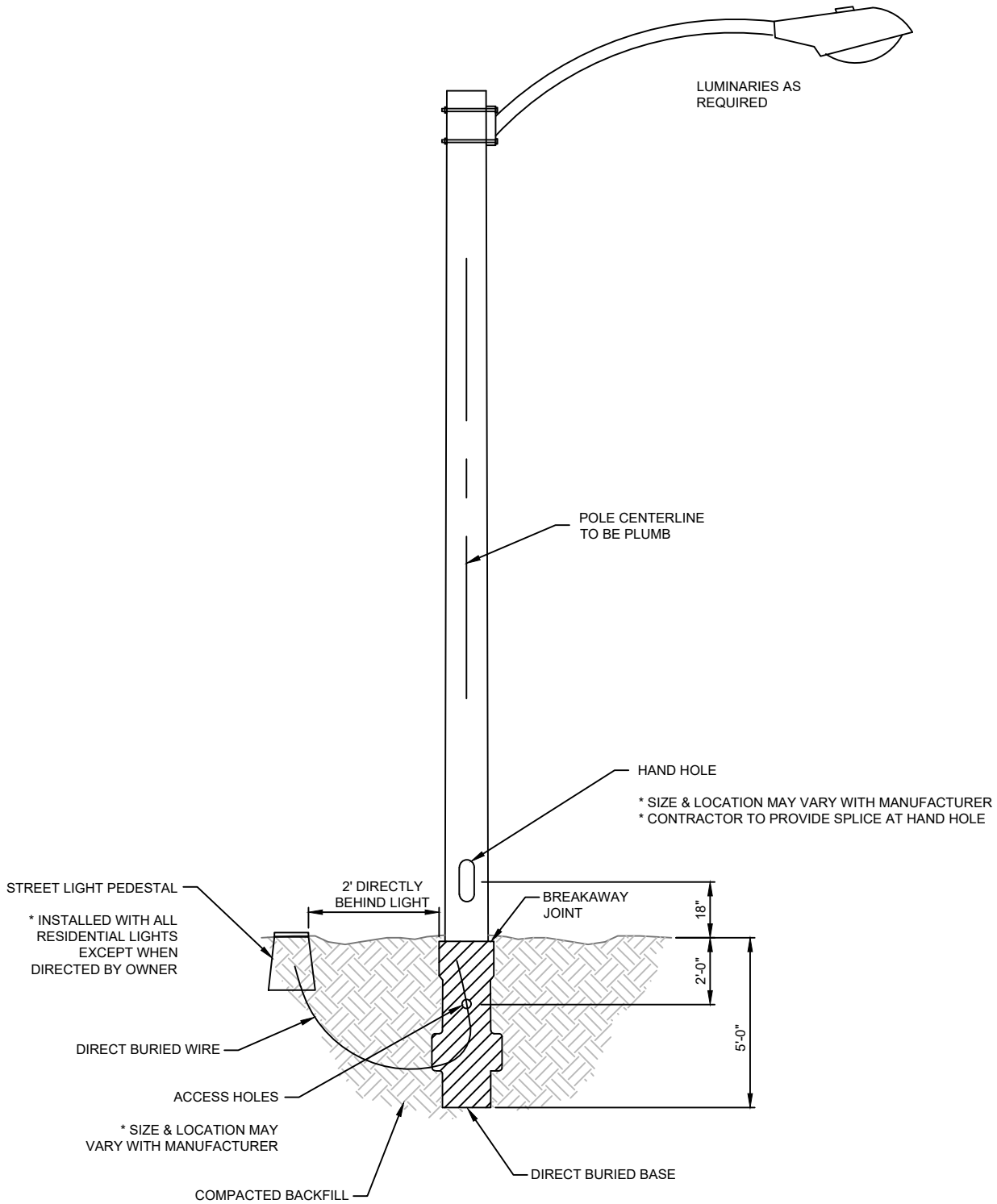

City Of Gillette  
 Department of Utilities  
 Electrical Engineering Division  
 611 N Exchange Ave  
 Gillette, WY 82717  
 307.686.5277

## STREET LIGHT DETAIL - DIRECT BURY RESIDENTIAL

Date: 2020-01-08  
 Drawing: stlt-res.dwg

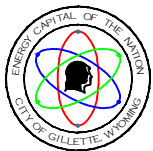
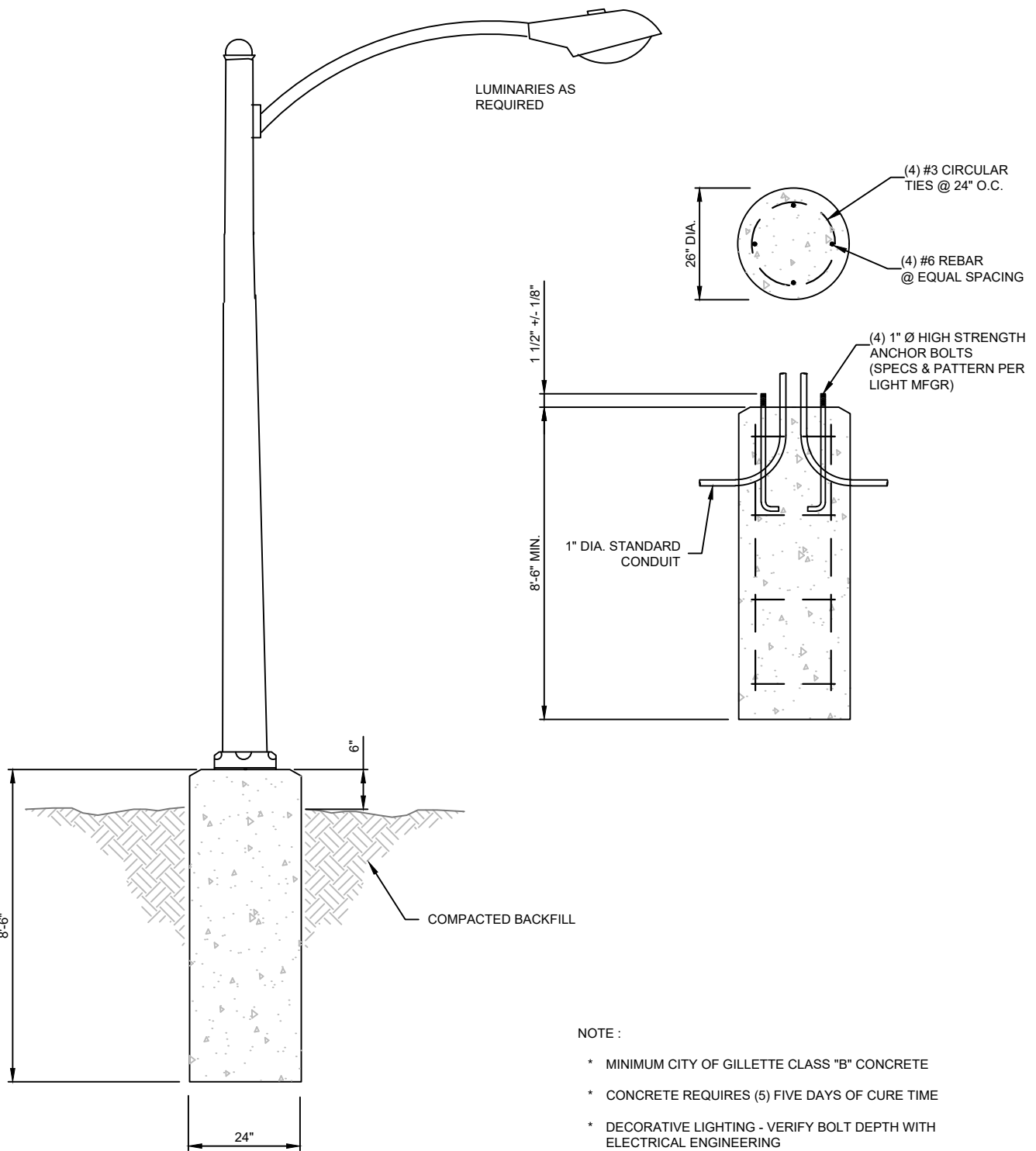

City Of Gillette  
 Department of Utilities  
 Electrical Engineering Division  
 611 N Exchange Ave  
 Gillette, WY 82717  
 307.686.5277

## STREET LIGHT & FOUNDATION DETAIL HIGHWAY

Date:  
 2016-09-28

Drawing:  
 stlt-hwy.dwg

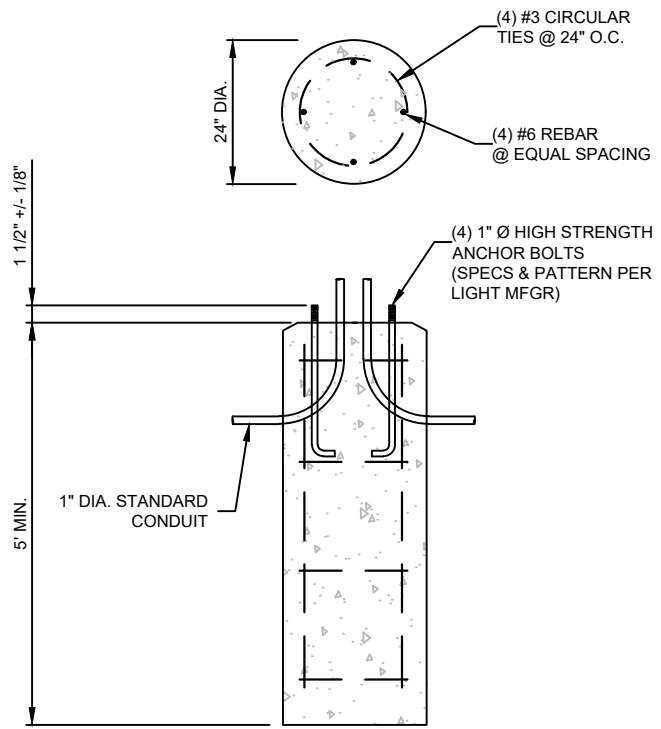
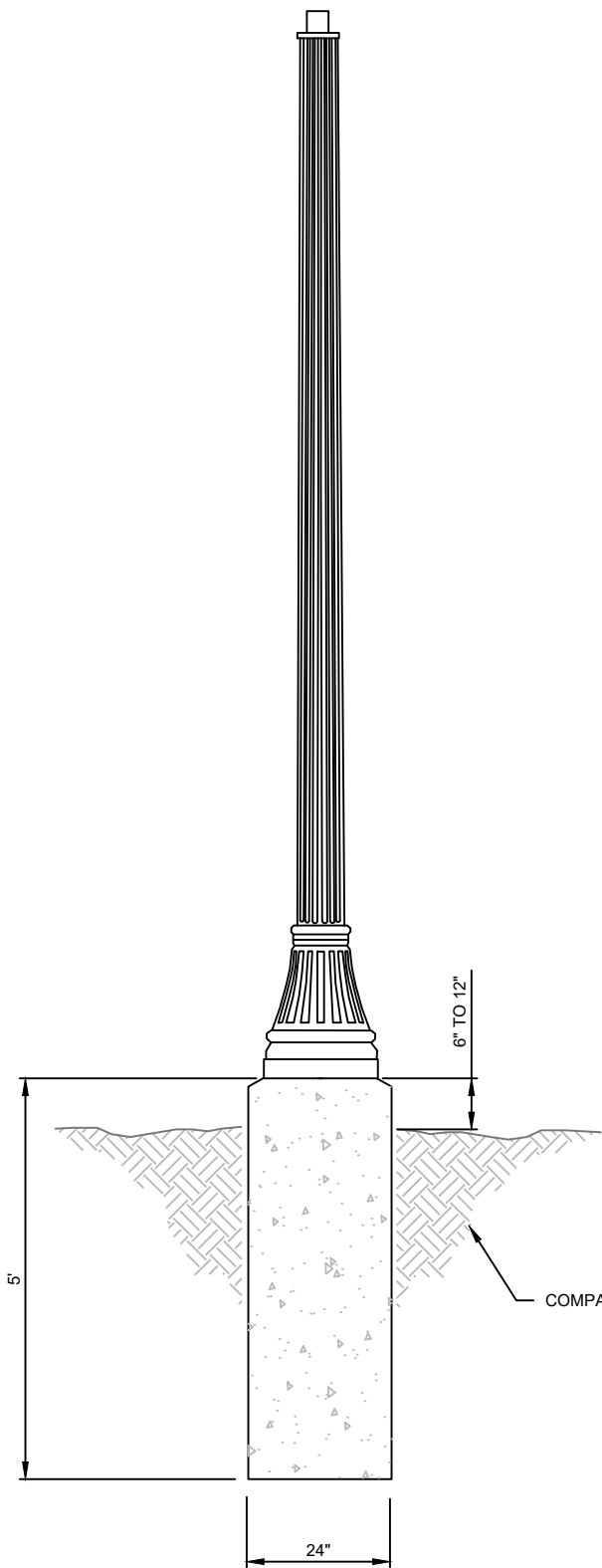

NOTE :

- \* MINIMUM CITY OF GILLETTE CLASS "B" CONCRETE
- \* CONCRETE REQUIRES (5) FIVE DAYS OF CURE TIME
- \* DECORATIVE LIGHTING - VERIFY BOLT DEPTH WITH ELECTRICAL ENGINEERING

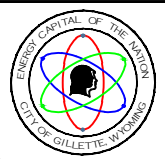

City Of Gillette  
 Department of Utilities  
 Electrical Engineering Division  
 611 N Exchange Ave  
 Gillette, WY 82717  
 307.686.5277

## STREET LIGHT & FOUNDATION DETAIL SHAKESPEARE ACORN

Date: 2016-09-28  
 Drawing: stlt-dec.dwg

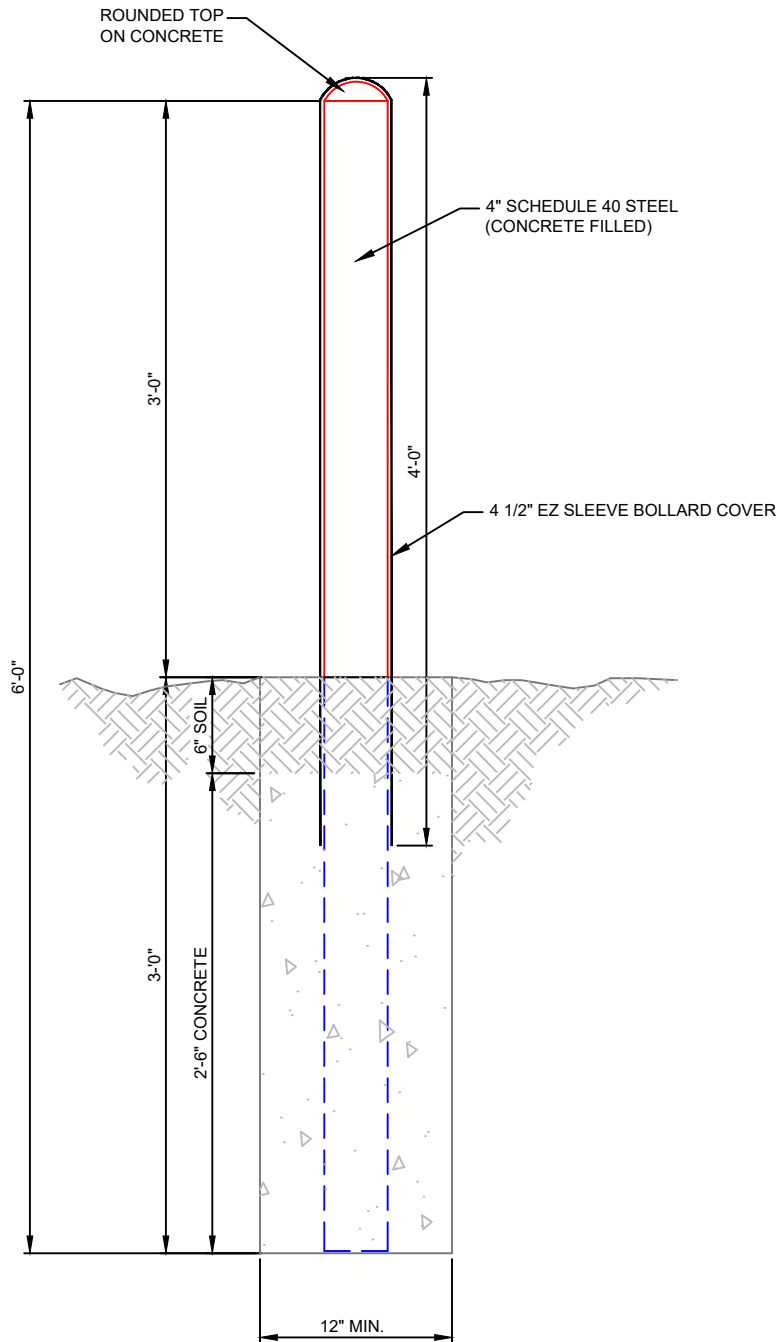

NOTE:

- \* DIAMETER OF BOLLARD TO BE SET BY ELECTRICAL SERVICES DIVISION
- \* CITY OF GILLETTE CLASS "B" CONCRETE SHALL BE REQUIRED

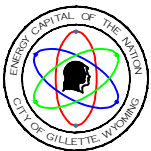

City Of Gillette  
 Department of Utilities  
 Electrical Engineering Division  
 611 N Exchange Ave  
 Gillette, WY 82717  
 307.686.5277

## TYPICAL BOLLARD DETAIL

Date: 2016-03-24

Drawing: bollard.dwg

MINIMUM 2X4 BLOCKING  
REQUIRED BETWEEN STUDS  
WHEN SOCKET CANNOT BE  
SECURED TO WALL STUDS

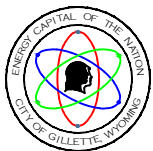
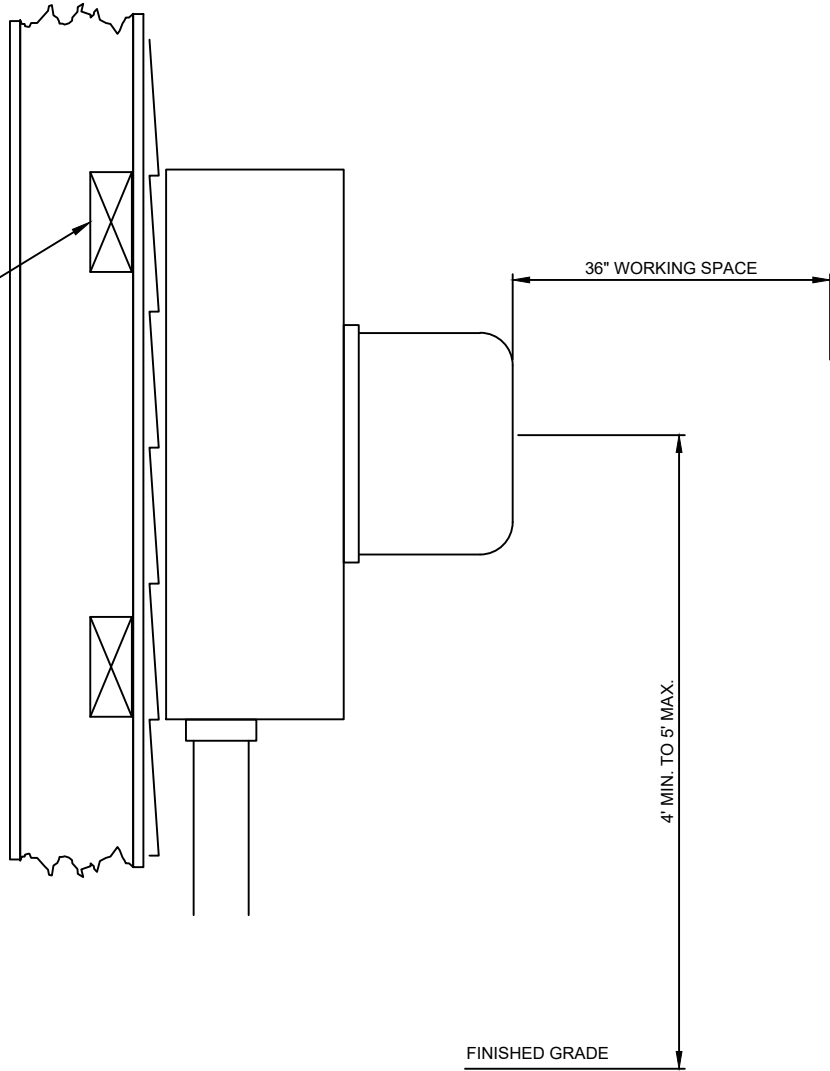

City Of Gillette  
Department of Utilities  
Electrical Engineering Division  
611 N Exchange Ave  
Gillette, WY 82717  
307.686.5277

## METER SOCKET INSTALLATION

Date:  
2016-02-11

Drawing:  
mtr-socket.dwg



CT CAN

36"(a)x36"(b)x8" - 3 PHASE

24"(a)x24"(b)x8" - 1 PHASE

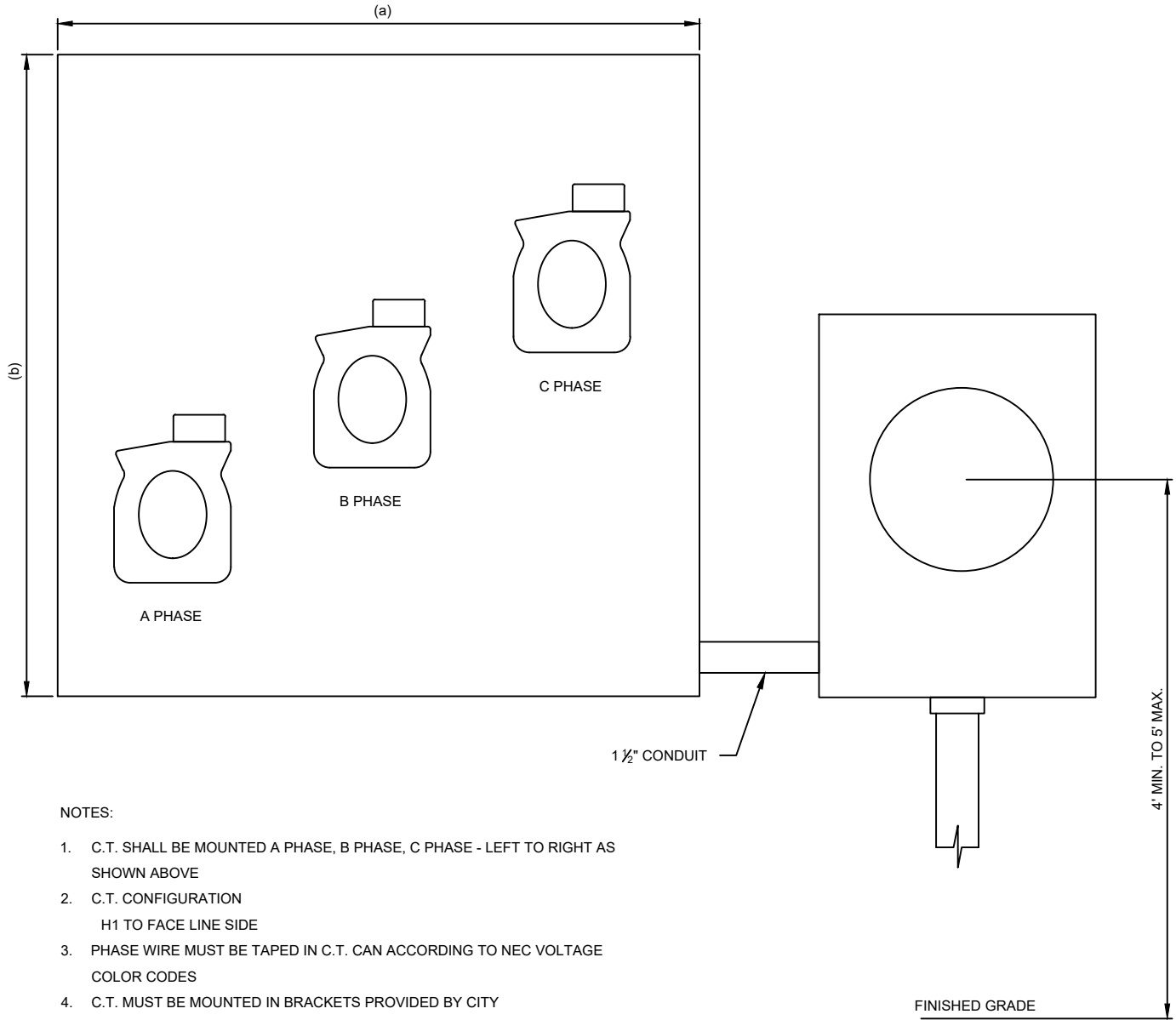

NOTES:

1. C.T. SHALL BE MOUNTED A PHASE, B PHASE, C PHASE - LEFT TO RIGHT AS SHOWN ABOVE
2. C.T. CONFIGURATION  
H1 TO FACE LINE SIDE
3. PHASE WIRE MUST BE TAPED IN C.T. CAN ACCORDING TO NEC VOLTAGE COLOR CODES
4. C.T. MUST BE MOUNTED IN BRACKETS PROVIDED BY CITY

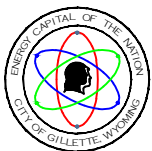

City Of Gillette  
Department of Utilities  
Electrical Engineering Division  
611 N Exchange Ave  
Gillette, WY 82717  
307.686.5277

CT CAN

Date:  
2022-03-30

Drawing:  
ct-can.dwg

## Appendix 2

---

### Available Fault Current Data

#### Approximate Available Fault Current Tables

Single Phase kVa	Voltage	
	120/240	240/480
10	3.9 kA	2.0 kA
15	6.9 kA	3.5 kA
25	9.8 kA	4.9 kA
37.5	12.3 kA	6.1 kA
50	20.8 kA	10.4 kA
75	24.5 kA	12.3 kA
100	36.6 kA	18.3 kA
167	43.9 kA	21.9 kA

Three Phase kVa	Voltage			
	120/240	120/208	240/480	277/480
45	13.9 kA	16.0 kA	6.9 kA	6.9 kA
75	18.0 kA	20.8 kA	9.0 kA	9.0 kA
112.5	19.0 kA	21.9 kA	9.5 kA	9.5 kA
150	30.1 kA	34.7 kA	15.0 kA	15.0 kA
225	45.1 kA	52.0 kA	22.6 kA	22.6 kA
300	70.8 kA	81.6 kA	35.4 kA	35.4 kA
500	78.4 kA	90.5 kA	39.2 kA	39.2 kA
750	42.2 kA	48.7 kA	21.1 kA	21.1 kA
1000	63.3 kA	73.0 kA	31.7 kA	31.7 kA
1500	105.5 kA	121.7 kA	52.8 kA	52.8 kA
2500	126.6 kA	146.1 kA	63.3 kA	63.3 kA

Fault currents shown are approximations for estimating purposes only. Values shown are at the secondary connections of transformers. Some values may vary significantly from those shown. Customers requiring more detail information should contact the City of Gillette's Electrical Services Division at (307) 686-5277.

## Appendix 3

---

### Net Metering

This rate is applicable for electrical customer owned parallel generation facilities of less than 25 kW. Generation equipment will be designed to be compatible with the characteristics of the service that the customer receives from the utility.

For each month, the City will record both the energy delivered to the customer and the energy received from the customer. If the energy delivered to the customer is greater than the energy received from the customer, the customer will be billed for the difference under the rate applicable to that electrical customer.

If the energy delivered by the City electrical system is less than the energy received from the customer, the customer will not be billed for energy in that billing period and the surplus energy will be carried forward to the next billing period. In the first billing period of each year, if the customer's account has a credit for energy received from that customer, the customer will be compensated for the surplus at a rate not less than the City's average avoided cost for energy for the previous calendar year.

The City will supply and install an electric meter that will record the power flow delivered to the customer and received from the customer. The customer will supply all other equipment needed to ensure operation of customer owned generation. A separate lockable disconnect is required for all service applicable to this rate. The disconnect shall be accessible to City electrical utility personnel at all times.

The customer will install and maintain a separate disconnecting means for the generator(s). This disconnect shall be located where it is accessible to City electrical utility personnel. The disconnect shall have provisions to be padlocked in the open position and provisions to allow its use in the Utility's energy control plans. The disconnect shall be labeled. If the generator disconnect is not located within sight of the utility supply disconnect, a plaque showing the location of all disconnects shall be placed by each disconnect serving the facility.

The Customer will maintain a Power Factor for the generation equipment between .9 leading and .9 lagging at all times. For purposes of this requirement, the Power Factor for the generator will be measured at the generation disconnect. If the customer fails to maintain the Power Factor within this range, the City may require the customer to disconnect the generation equipment from interconnection with the City's system until the customer can demonstrate compliance.

The Customer is responsible for compliance with all applicable codes and standards, including but not limited to the National Electrical Code, the National Electric Safety Code, IEEE standard 1547 and the City of Gillette's Electrical Distribution Standards. The Electrical Services Division will review the generation equipment and its installation to ensure that it will be compatible with the City electrical distribution system and their approval is required before the generation equipment shall be connected to the City electrical distribution system and energized. The Customer will allow utility access to the generator's disconnecting means to allow utility staff to perform measurements to independently verify compliance with the above referenced

codes and standards. In accordance with IEEE Standard 1547, the generation equipment shall automatically disconnect from the utility's system in the event of loss of utility supply to the customer's meter. (Ord. 3745, 12-19-2011)

# Appendix 4

---

## Capital Contribution Fee

Anyone who requires connection to the City of Gillette’s electrical distribution system shall pay a Capital Contribution Fee. This Capital Contribution Fee is intended to be a contribution to the capital cost of providing electrical distribution services. In the case of an expansion of an existing service, the Capital Contribution Fee shall only be for the amount by which the service is expanded from the existing service. The amount of the Capital Contribution Fee shall be adjusted by the City of Gillette from time to time, taking into account the current cost of material, equipment, labor and overhead expenses. In case of multiple services per building, the service entrance size shall be based on total service disconnect sizing. The Capital Contribution Fee is based on the total service disconnect size.

All Capital Contribution Fees shall be paid prior to the issuance of a Building Permit for this project or an Electrical permit if no Building Permit is issued. Capital Contribution Fees may not be transferred and may not be paid by Plant Investment Fee Credits. (Ord. 3497, 7-2-2007; Ord. 3538, 3-3-2008).

### Electrical Utility System Service Size Capital Contribution Schedule

Service Size	Voltage	Fee for each 100 amps of service or part thereof
<b>Single Phase</b>	120/240	\$175.00
	120/208	\$180.00
<b>Three Phase</b>	120/208	\$315.00
	277/480	\$727.00

Costs for service voltages other than those shown above will be calculated on a dollar per kVA basis by the Gillette Utility Department.